

- ELEMENTOS EXISTENTES
- ELEMENTOS A SEREM DEMOLIDOS
- ELEMENTOS A SEREM ACRESCIDOS



**PREFEITURA MUNICIPAL DE IGARATINGA - MG**

**REFORMA DO ESTÁDIO DONA ROGELINA**

LOGRADOURO: RUA CÂNDIDO JOSÉ DA SILVA / RUA JOSÉ BARREIRO / RUA PADRE EVANISTO  
 BAIRRO: CENTRO (DISTRITO DE ANTUNES)  
 IGARATINGA - MG CEP: 35695-000

RESPONSÁVEL TÉCNICO:  
 FLÁVIO L. GRECO S.  
 ENGº CIVIL - CREA-MG: 64.880/D

PROPRIETÁRIO:  
 PREFEITURA MUNICIPAL DE IGARATINGA  
 CPNJ: 18.313.825/0001-21

ESCALA: 1/200      DATA: AGOSTO/2023      FOLHA: 01



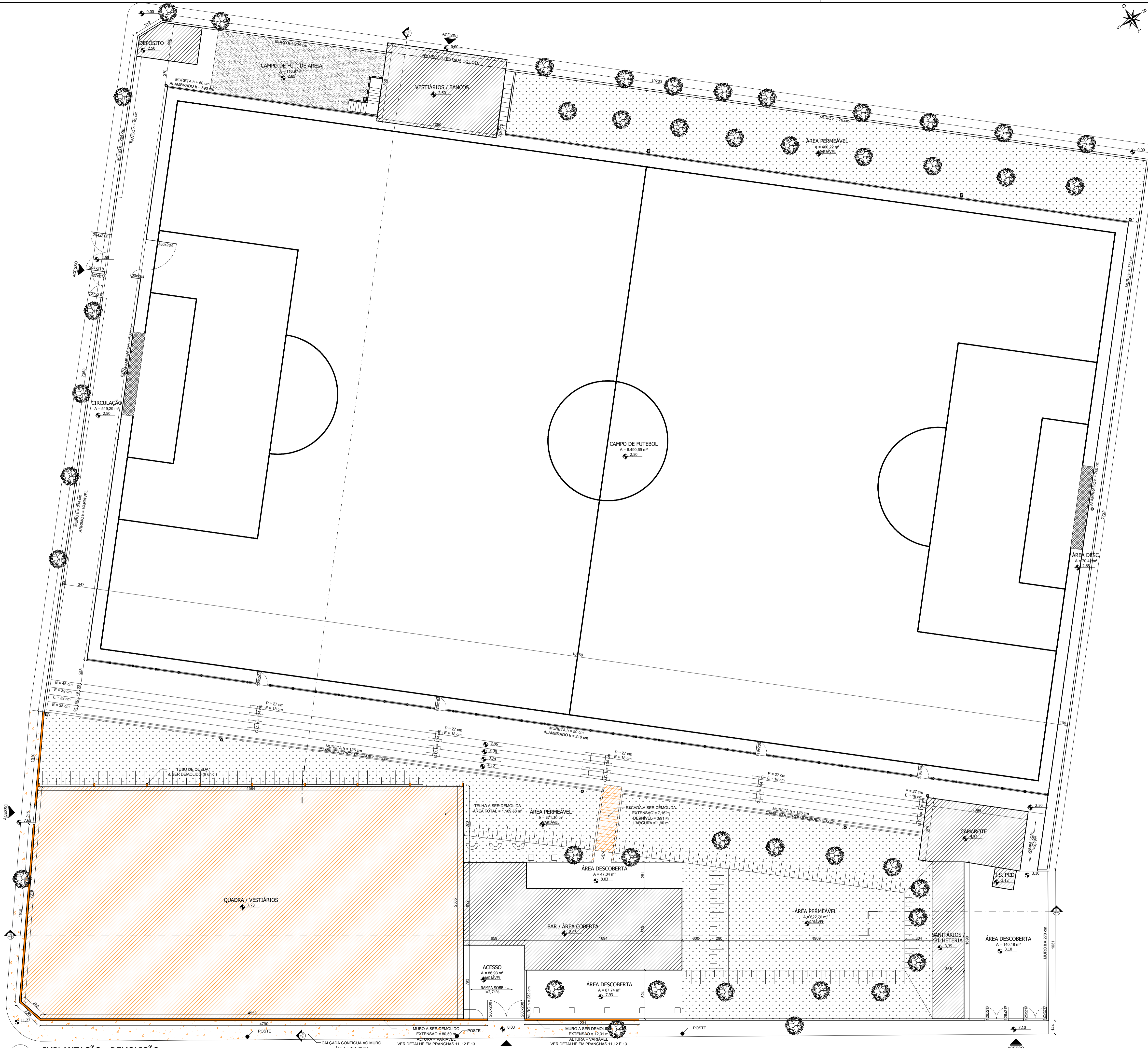

- ELEMENTOS EXISTENTES
- ELEMENTOS A SEREM DEMOLIDOS
- ELEMENTOS A SEREM ACRESCIDOS



**PREFEITURA MUNICIPAL DE IGARATINGA - MG**

---

**REFORMA DO ESTÁDIO DONA ROGELINA**

---

LOGRADOURO: RUA CÂNDIDO JOSÉ DA SILVA / RUA JOSÉ BARREIRO / RUA PADRE EVANISTO  
 BAIRRO: CENTRO (DISTRITO DE ANTUNES)  
 IGARATINGA - MG CEP: 35695-000

---

RESPONSÁVEL TÉCNICO:  FLÁVIO L. GRECO S. ENGº CIVIL - CREA-MG: 64.880/D	PROPRIETÁRIO:  PREFEITURA MUNICIPAL DE IGARATINGA CPNJ: 18.313.825/0001-21
--	---

---

ESCALA: 1/200	DATA: AGOSTO/2023	FOLHA: 02
---------------	-------------------	-----------



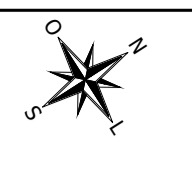
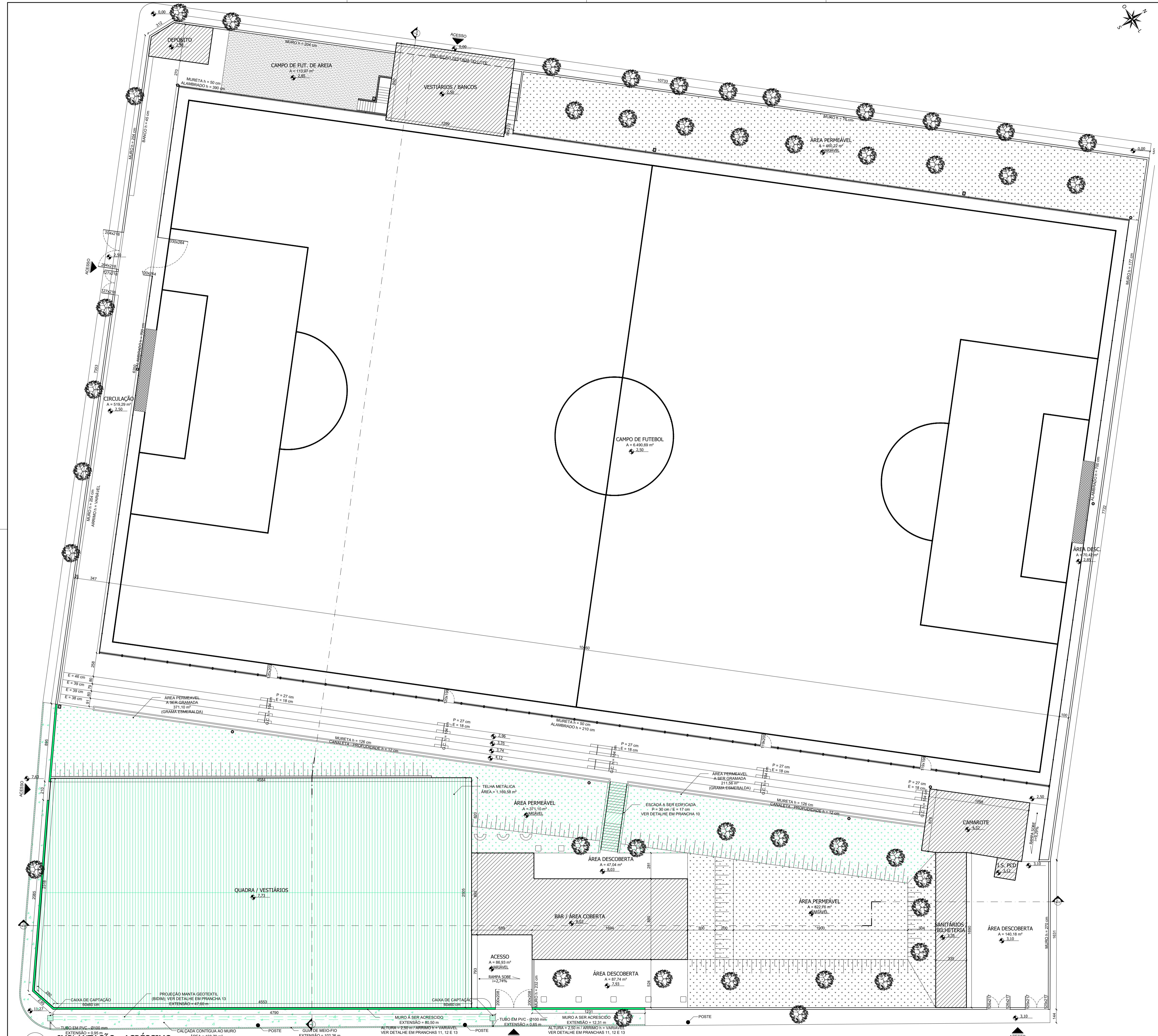

- ELEMENTOS EXISTENTES
- ELEMENTOS A SEREM DEMOLIDOS
- ELEMENTOS A SEREM ACRESCIDOS



**PREFEITURA MUNICIPAL DE IGARATINGA - MG**

**REFORMA DO ESTÁDIO DONA ROGELINA**

LOGRADOURO: RUA CÂNDIDO JOSÉ DA SILVA / RUA JOSÉ BARREIRO / RUA PADRE EVANISTO  
 BAIRRO: CENTRO (DISTRITO DE ANTUNES)  
 IGARATINGA - MG CEP: 35695-000

RESPONSÁVEL TÉCNICO:  
 FLÁVIO L. GRECO S.  
 ENGº CIVIL - CREA-MG: 64.880/D

PROPRIETÁRIO:  
 PREFEITURA MUNICIPAL DE IGARATINGA  
 CPNJ: 18.313.825/0001-21

ESCALA: 1/200

DATA: AGOSTO/2023

FOLHA: 03



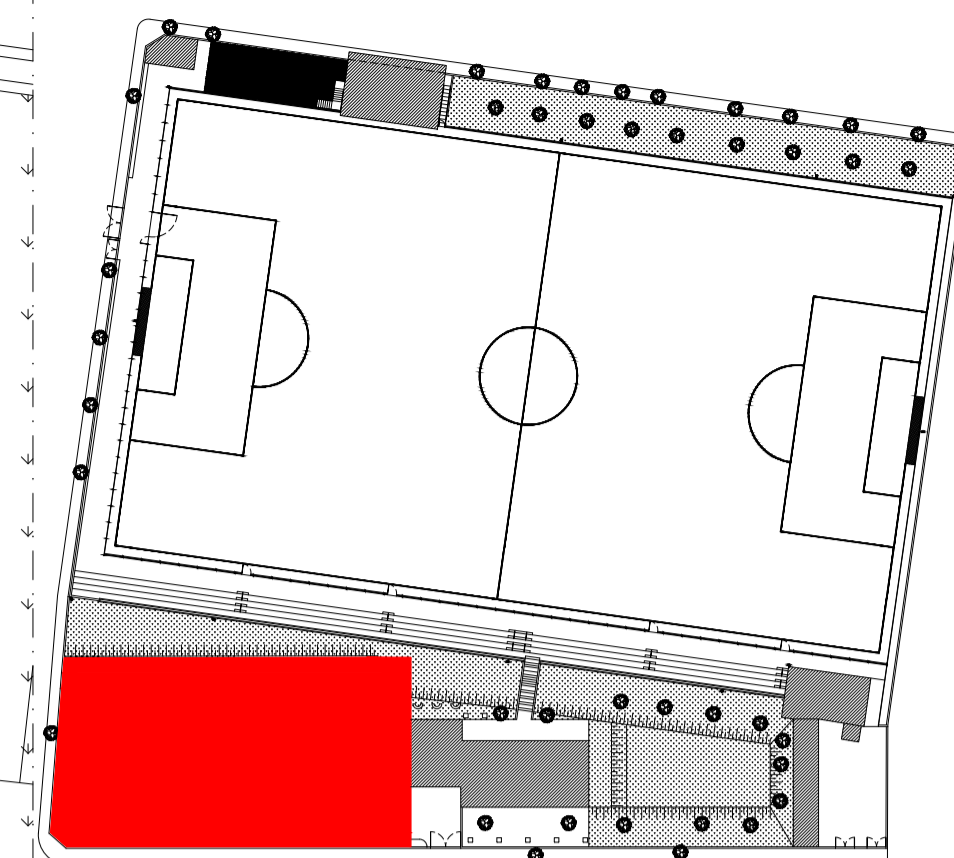
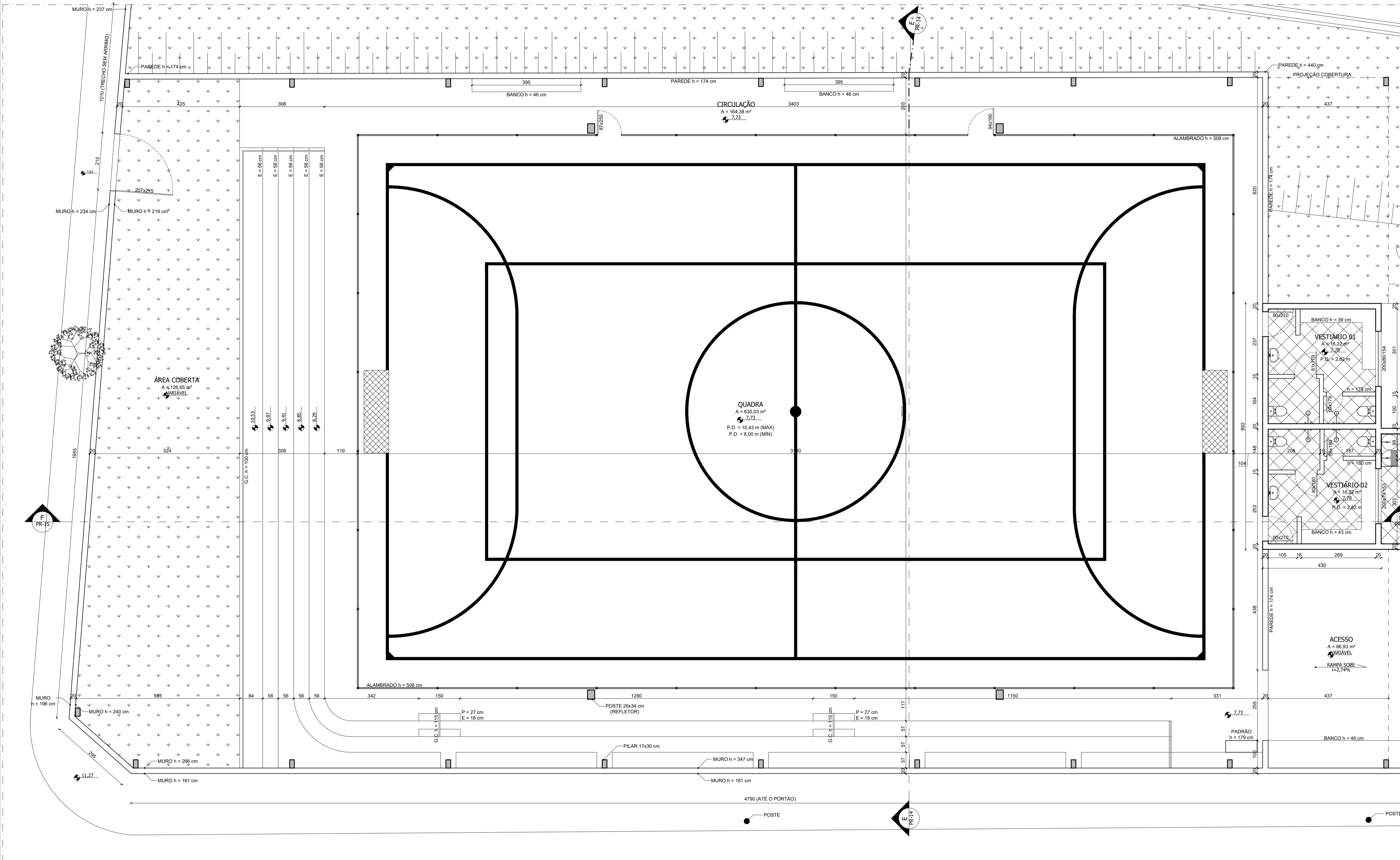

- ELEMENTOS EXISTENTES
- ELEMENTOS A SEREM DEMOLIDOS
- ELEMENTOS A SEREM ACRESCIDOS

04 PLANTA - QUADRA (EXISTENTE)  
ESCALA 1:75



**PREFEITURA MUNICIPAL DE IGARATINGA - MG**

---

**REFORMA DO ESTÁDIO DONA ROGELINA**

---

LOGRADOURO: RUA CÂNDIDO JOSÉ DA SILVA / RUA JOSÉ BARREIRO / RUA PADRE EVANISTO  
BAIRRO: CENTRO (DISTRITO DE ANTUNES)  
IGARATINGA - MG CEP: 35695-000

RESPONSÁVEL TÉCNICO:  FLÁVIO L. GRECO S. ENGº CIVIL - CREA-MG/64.880/D	PROPRIETÁRIO:  PREFEITURA MUNICIPAL DE IGARATINGA CPNJ: 18.313.825/0001-21
---	---

---

ESCALA: 1/75	DATA: AGOSTO/2023	FOLHA: 04
--------------	-------------------	-----------



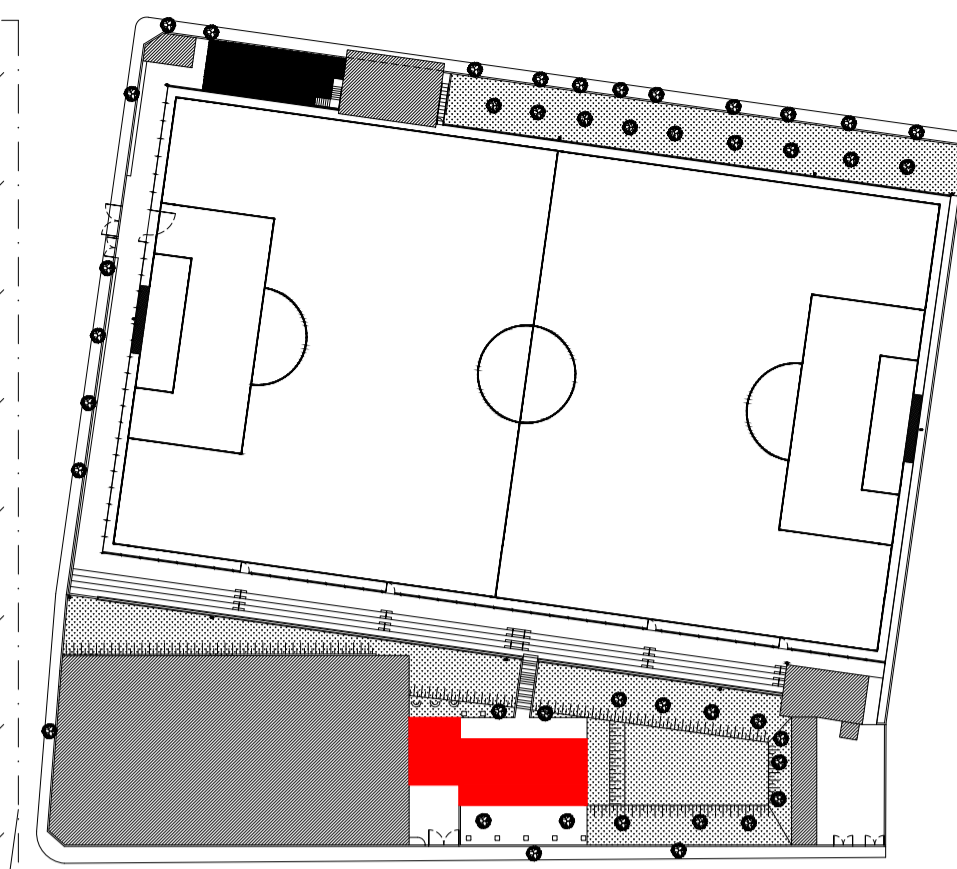
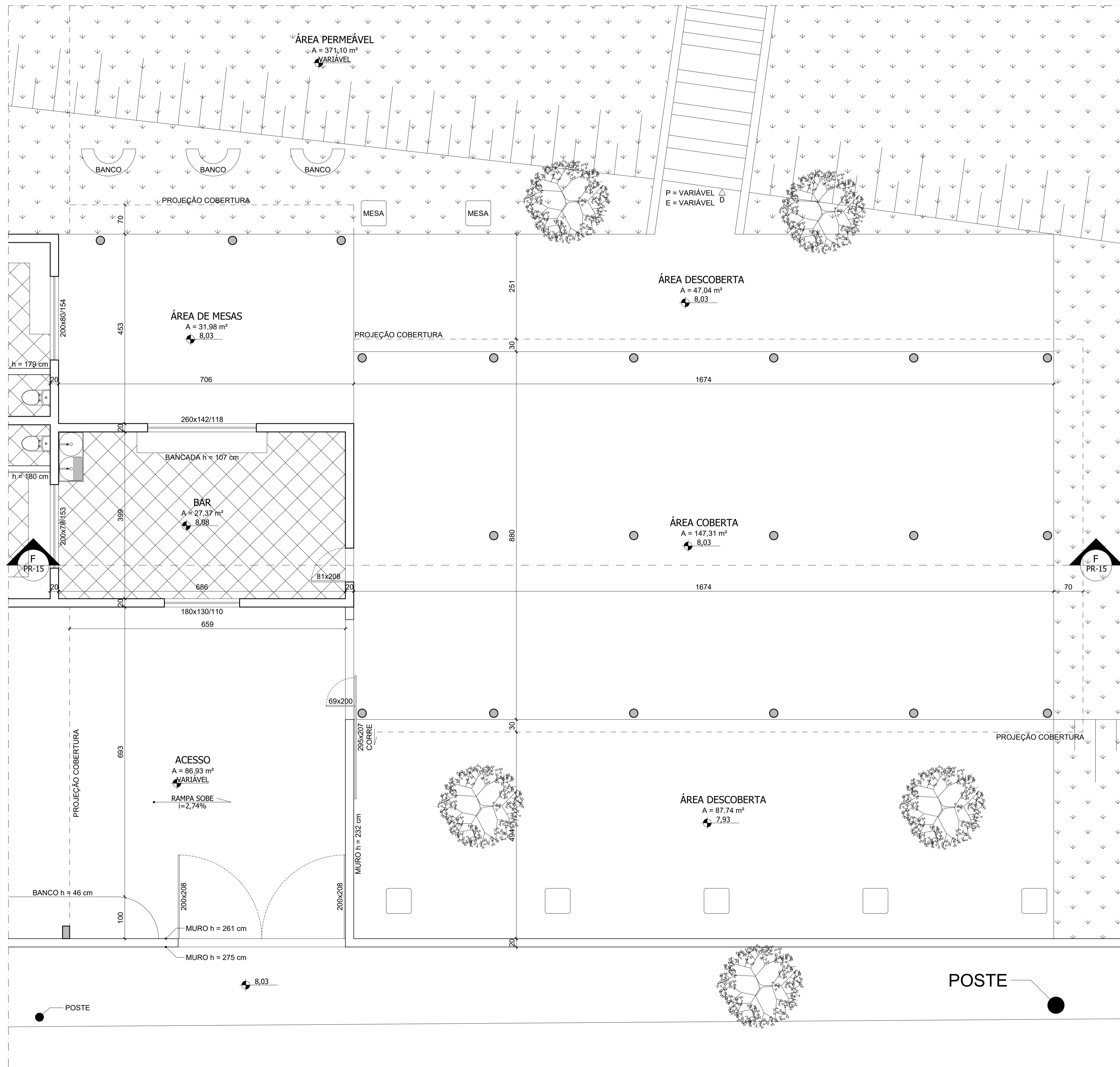

- ELEMENTOS EXISTENTES
- ELEMENTOS A SEREM DEMOLIDOS
- ELEMENTOS A SEREM ACRESCIDOS



**PREFEITURA MUNICIPAL DE IGARATINGA - MG**

**REFORMA DO ESTÁDIO DONA ROGELINA**

LOGRADOURO: RUA CÂNDIDO JOSÉ DA SILVA / RUA JOSÉ BARREIRO / RUA PADRE EVANISTO  
 BAIRRO: CENTRO (DISTRITO DE ANTUNES)  
 IGARATINGA - MG CEP: 35695-000

RESPONSÁVEL TÉCNICO:

PROPRIETÁRIO:

FLÁVIO L. GRECO S.  
 ENGº CIVIL - CREA-MG: 64.880/D

PREFEITURA MUNICIPAL DE IGARATINGA  
 CPNJ: 18.313.825/0001-21

ESCALA: 1/50

DATA: AGOSTO/2023

FOLHA: 05



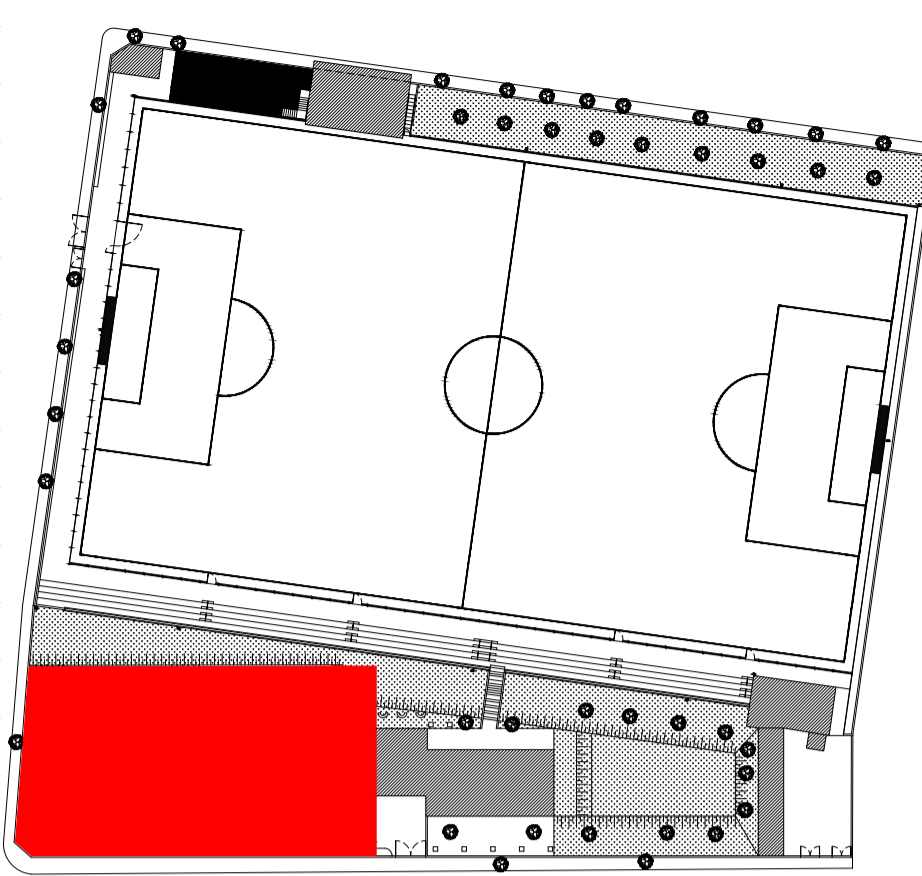
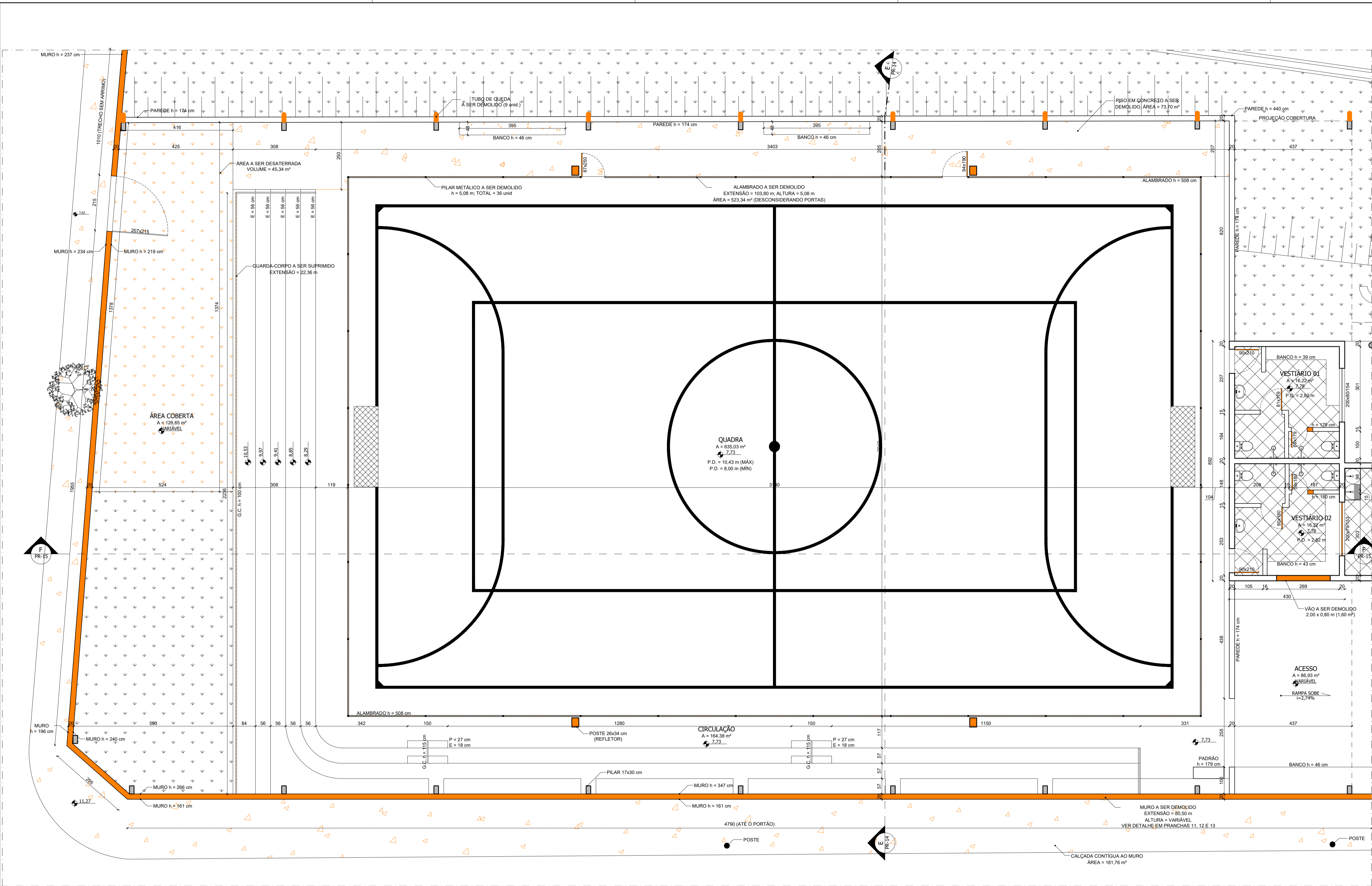

06 PLANTA - QUADRA (DEMOLIÇÃO)  
ESCALA 1:75

**PREFEITURA MUNICIPAL DE IGARATINGA - MG**

**REFORMA DO ESTÁDIO DONA ROGELINA**

LOGRADOURO: RUA CÂNDIDO JOSÉ DA SILVA / RUA JOSÉ BARREIRO / RUA PADRE EVANISTO  
BAIRRO: CENTRO (DISTRITO DE ANTUNES)  
IGARATINGA - MG CEP: 35695-000

RESPONSÁVEL TÉCNICO:  FLÁVIO L. GRECO S. ENGº CIVIL - CREA-MG: 64.880/D	PROPRIETÁRIO:  PREFEITURA MUNICIPAL DE IGARATINGA CPNJ: 18.313.825/0001-21
--	---



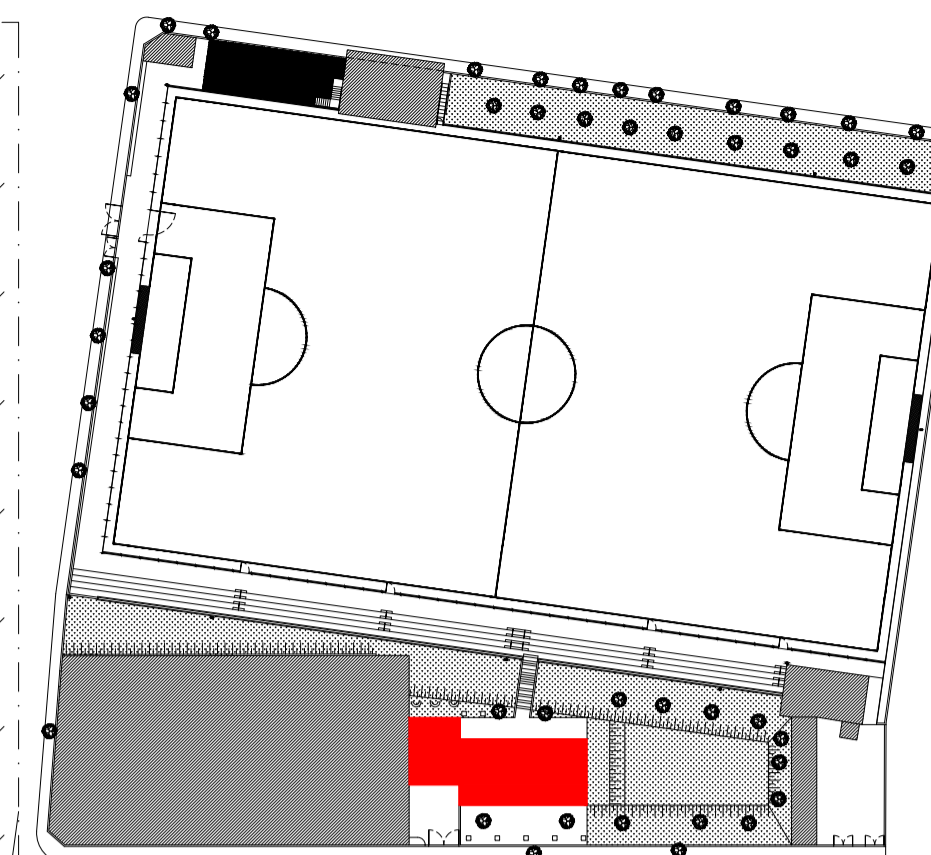
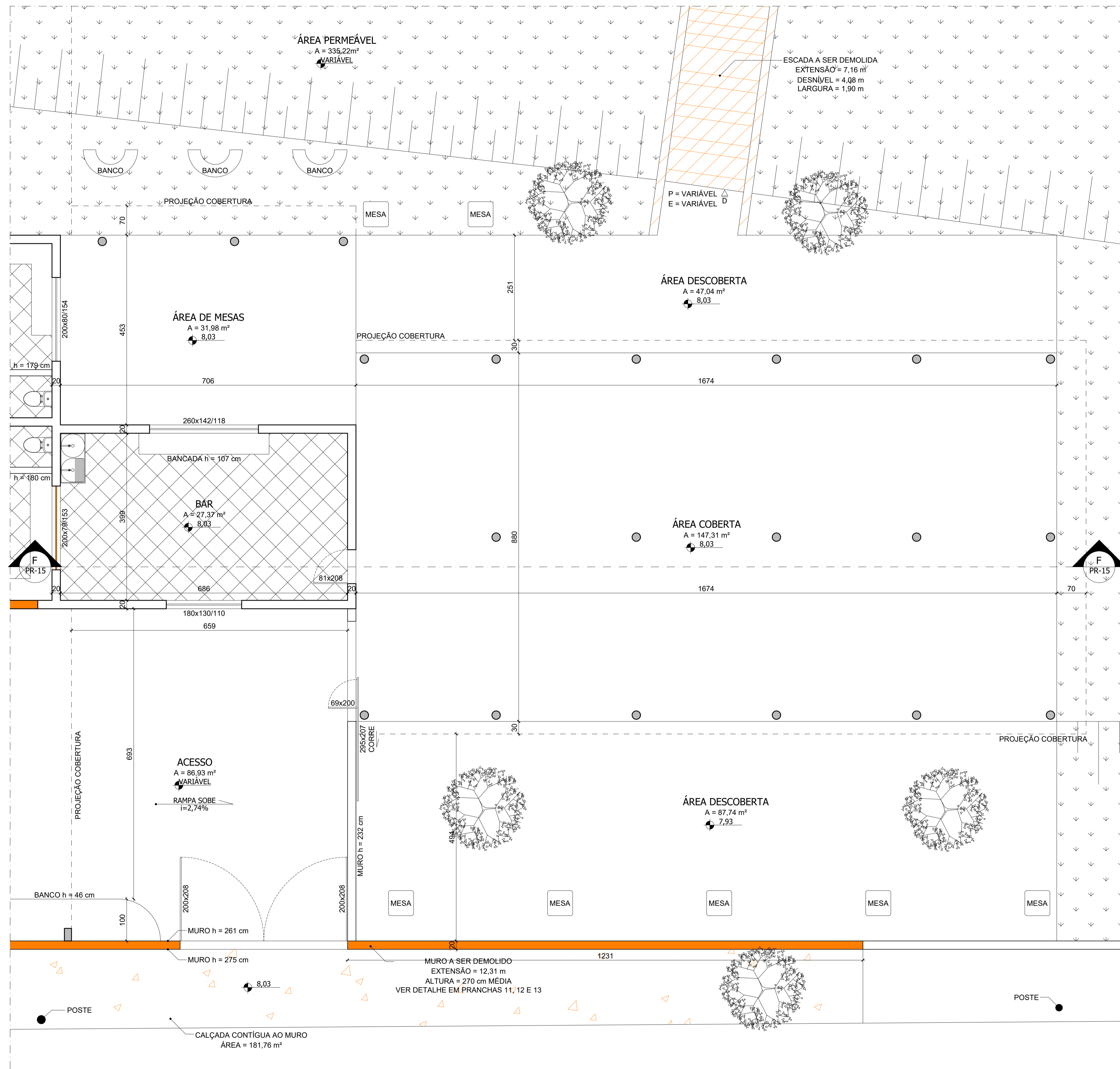

- ELEMENTOS EXISTENTES
- ELEMENTOS A SEREM DEMOLIDOS
- ELEMENTOS A SEREM ACRESCIDOS



**PREFEITURA MUNICIPAL DE IGARATINGA - MG**

**REFORMA DO ESTÁDIO DONA ROGELINA**

LOGRADOURO: RUA CÂNDIDO JOSÉ DA SILVA / RUA JOSÉ BARREIRO / RUA PADRE EVANISTO  
 BAIRRO: CENTRO (DISTRITO DE ANTUNES)  
 IGARATINGA - MG CEP: 35695-000

RESPONSÁVEL TÉCNICO:

PROPRIETÁRIO:

FLÁVIO L. GRECO S.  
 ENGO CIVIL - CREA-MG: 64.880/D

PREFEITURA MUNICIPAL DE IGARATINGA  
 CPNJ: 18.313.825/0001-21

ESCALA: 1/50

DATA: AGOSTO/2023

FOLHA: 07



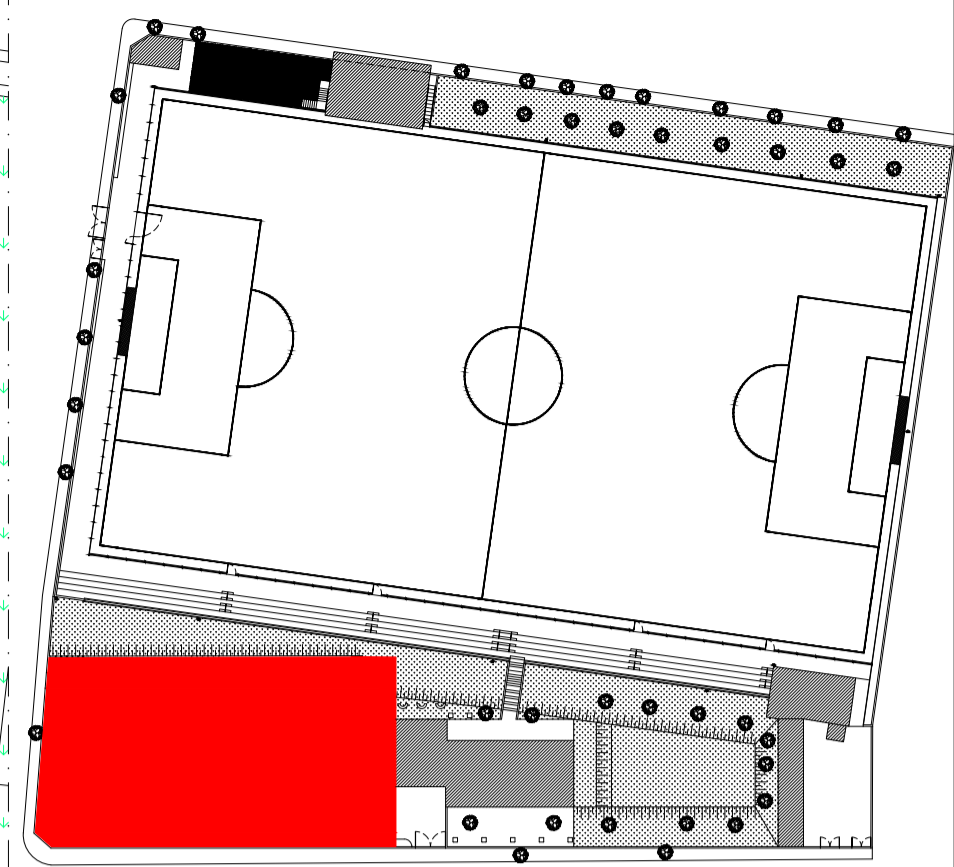
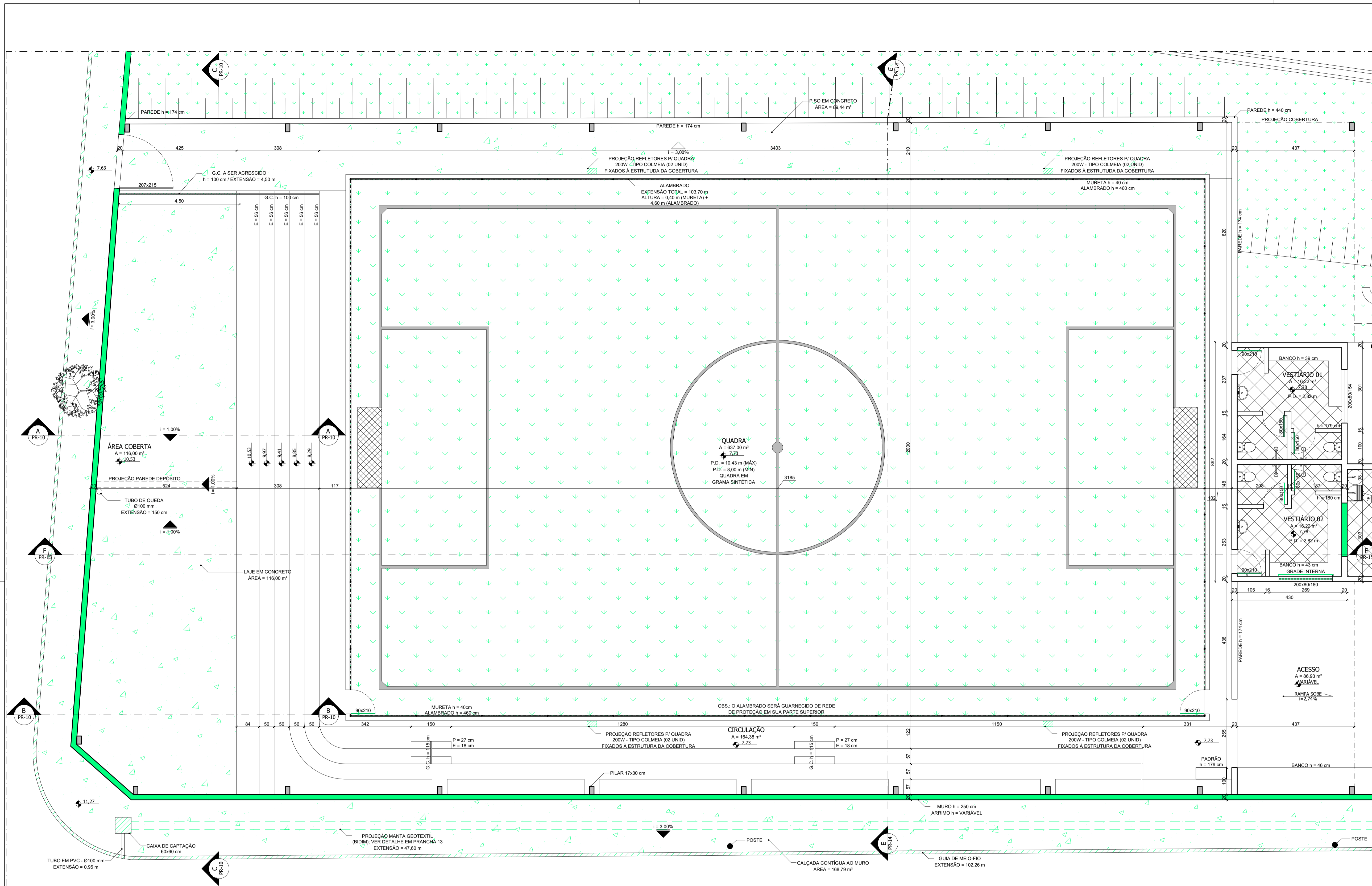

- ELEMENTOS EXISTENTES
- ELEMENTOS A SEREM DEMOLIDOS
- ELEMENTOS A SEREM ACRESCIDOS

08 PLANTA - QUADRA (ACRÉSCIMO)  
ESCALA 1:75



## PREFEITURA MUNICIPAL DE IGARATINGA - MG

### REFORMA DO ESTÁDIO DONA ROGELINA

LOGRADOURO: RUA CÂNDIDO JOSÉ DA SILVA / RUA JOSÉ BARREIRO / RUA PADRE EVANISTO  
BAIRRO: CENTRO (DISTRITO DE ANTUNES)  
IGARATINGA - MG CEP: 35695-000

RESPONSÁVEL TÉCNICO:  FLÁVIO L. GRECO S. ENGº CIVIL - CREA-MG: 64.880/D	PROPRIETÁRIO:  PREFEITURA MUNICIPAL DE IGARATINGA CPNJ: 18.313.825/0001-21
ESCALA: 1/75	DATA: AGOSTO/2023
FOLHA: 08	



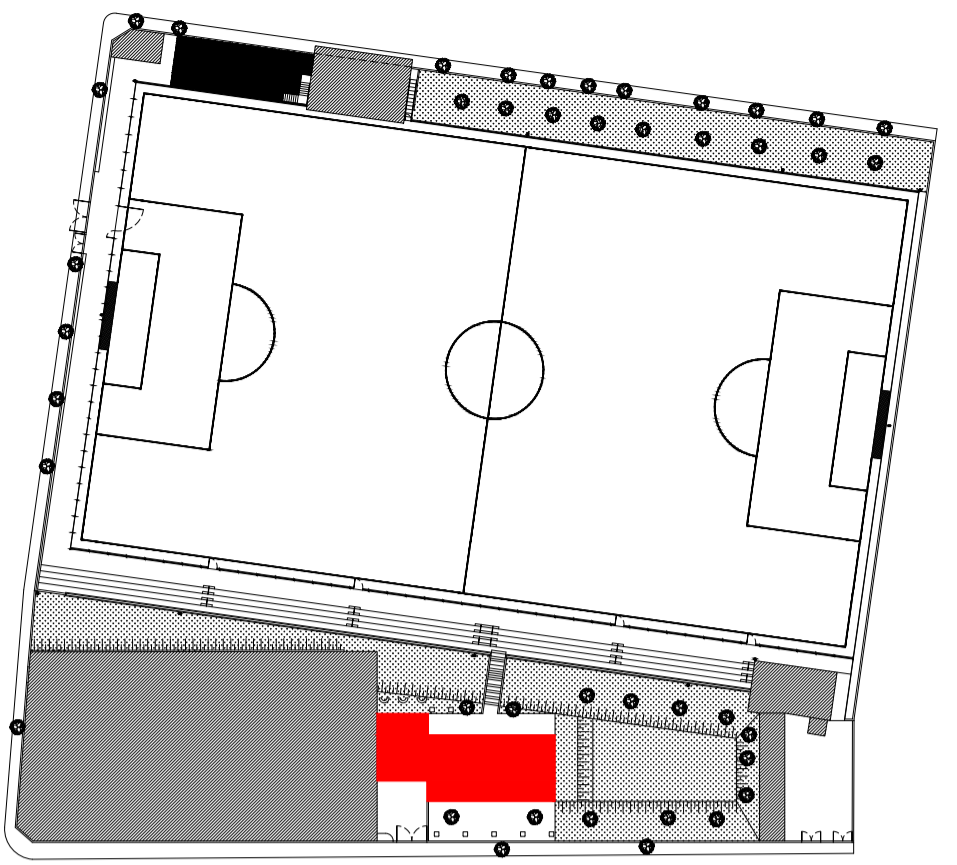
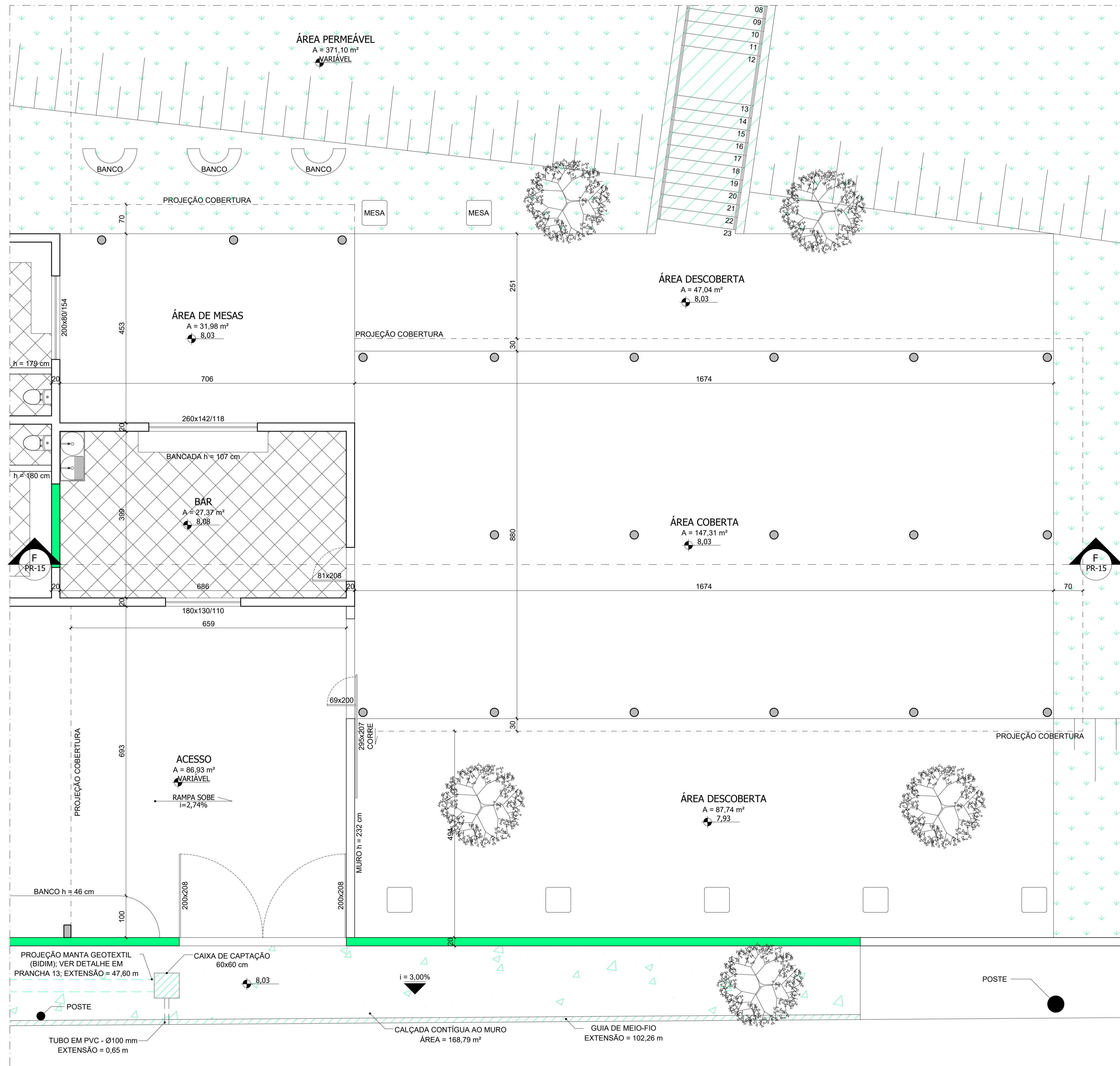

- ELEMENTOS EXISTENTES
- ELEMENTOS A SEREM DEMOLIDOS
- ELEMENTOS A SEREM ACRESCIDOS



**PREFEITURA MUNICIPAL DE IGARATINGA - MG**

**REFORMA DO ESTÁDIO DONA ROGELINA**

LOGRADOURO: RUA CÂNDIDO JOSÉ DA SILVA / RUA JOSÉ BARREIRO / RUA PADRE EVANISTO  
 BAIRRO: CENTRO (DISTRITO DE ANTUNES)  
 IGARATINGA - MG CEP: 35695-000

RESPONSÁVEL TÉCNICO:  
 FLÁVIO L. GRECO S.  
 ENGO CIVIL - CREA-MG: 64.880/D

PROPRIETÁRIO:  
 PREFEITURA MUNICIPAL DE IGARATINGA  
 CPNJ: 18.313.825/0001-21

ESCALA: 1/50 DATA: AGOSTO/2023 FOLHA: 09

**09 PLANTA - BAR (ACRÉSCIMO)**  
 ESCALA 1:50



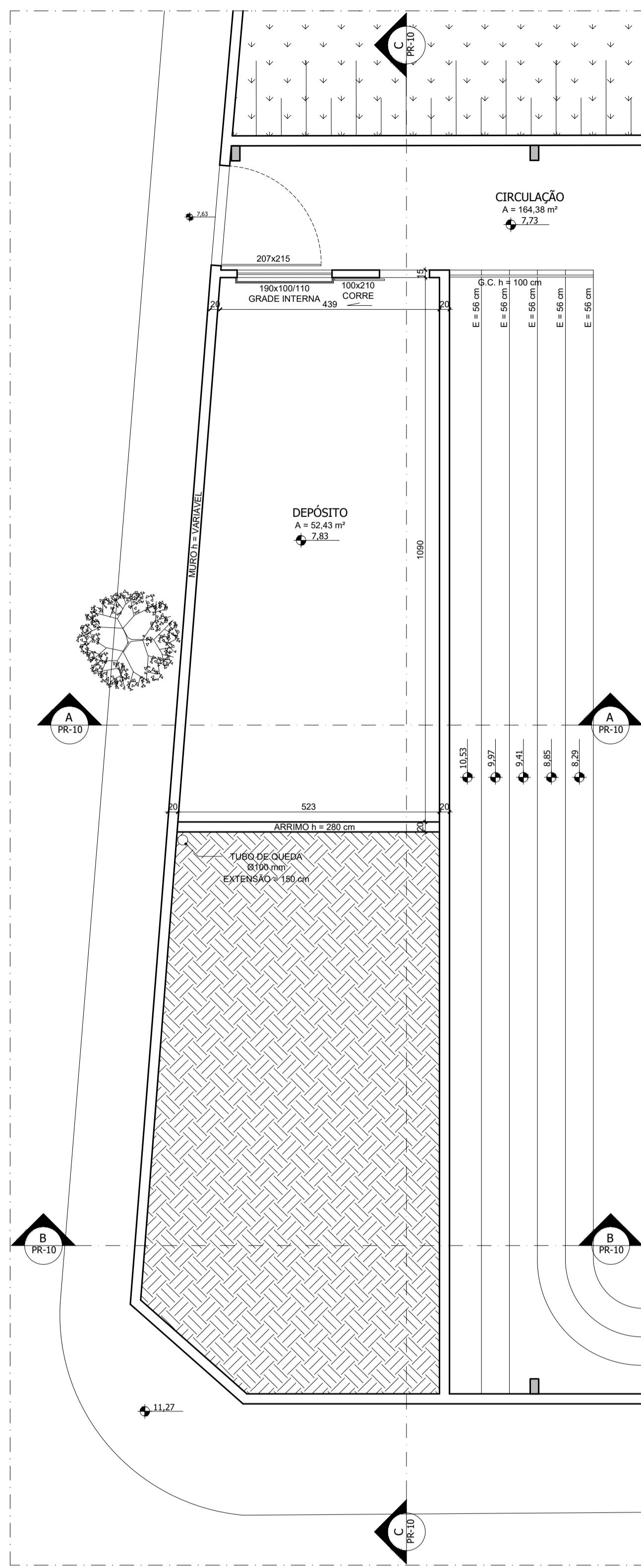

10 PLANTA - DEPÓSITO  
ESCALA 1:75

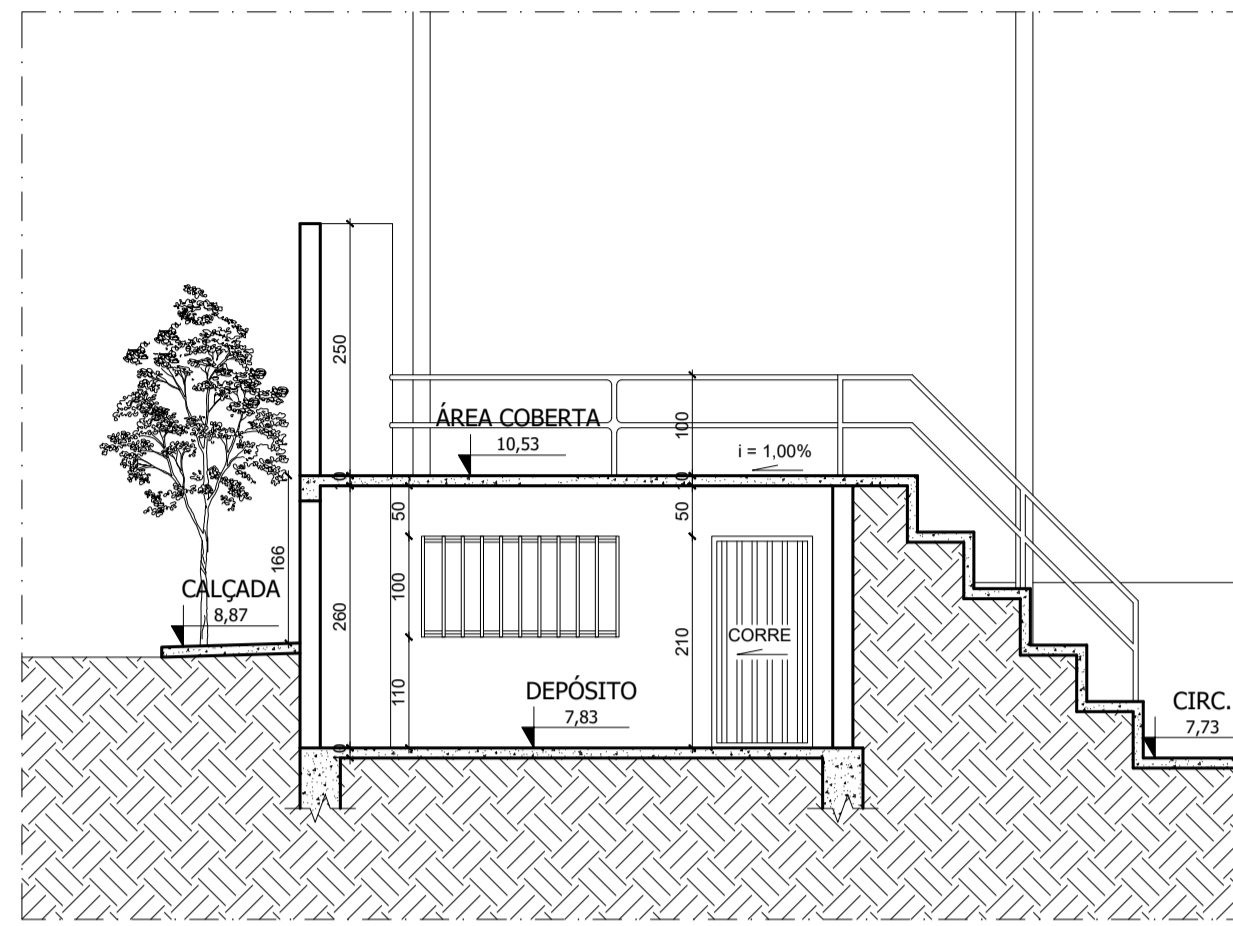

11 CORTE AA  
ESCALA 1:75

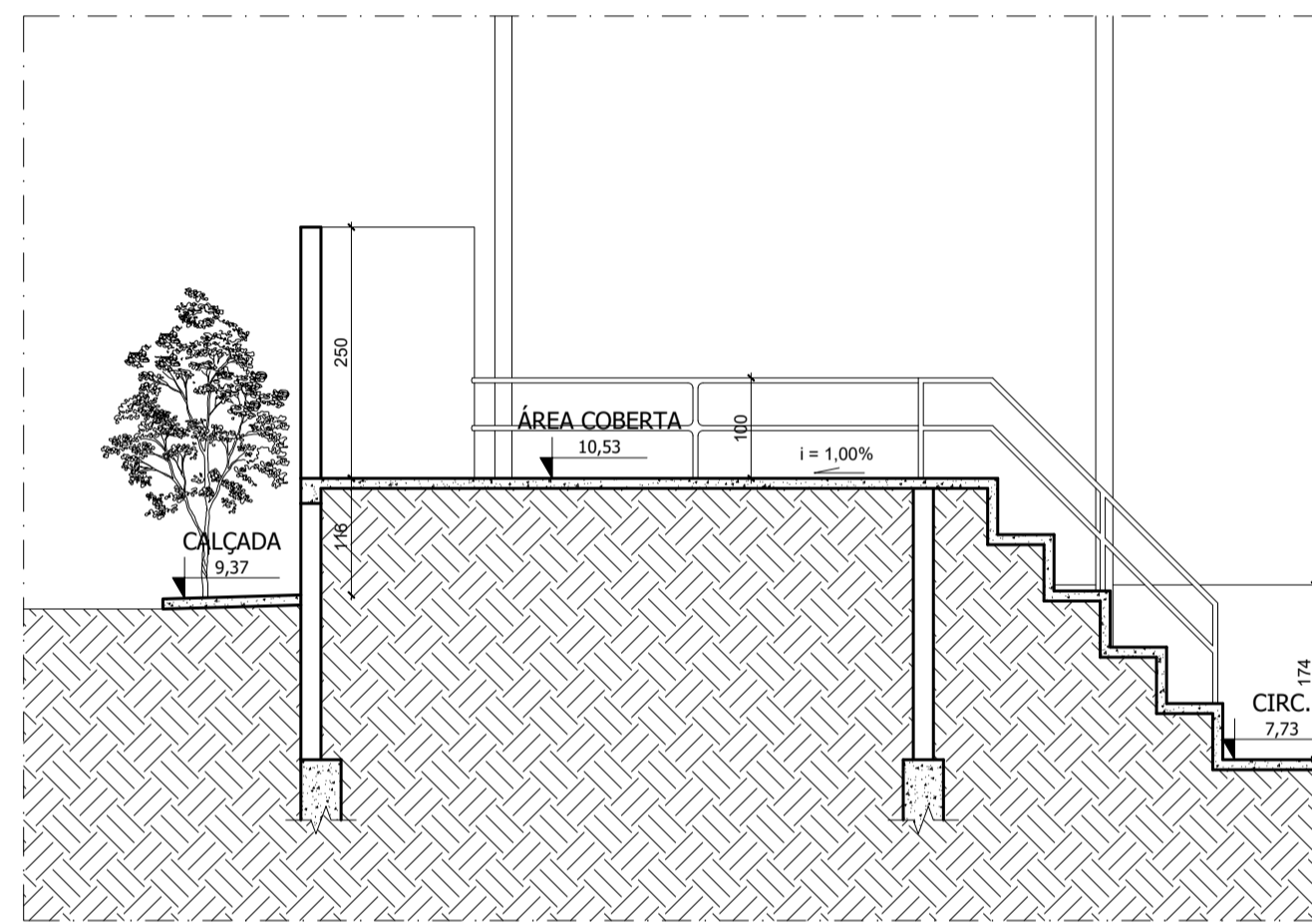

12 CORTE BB  
ESCALA 1:75

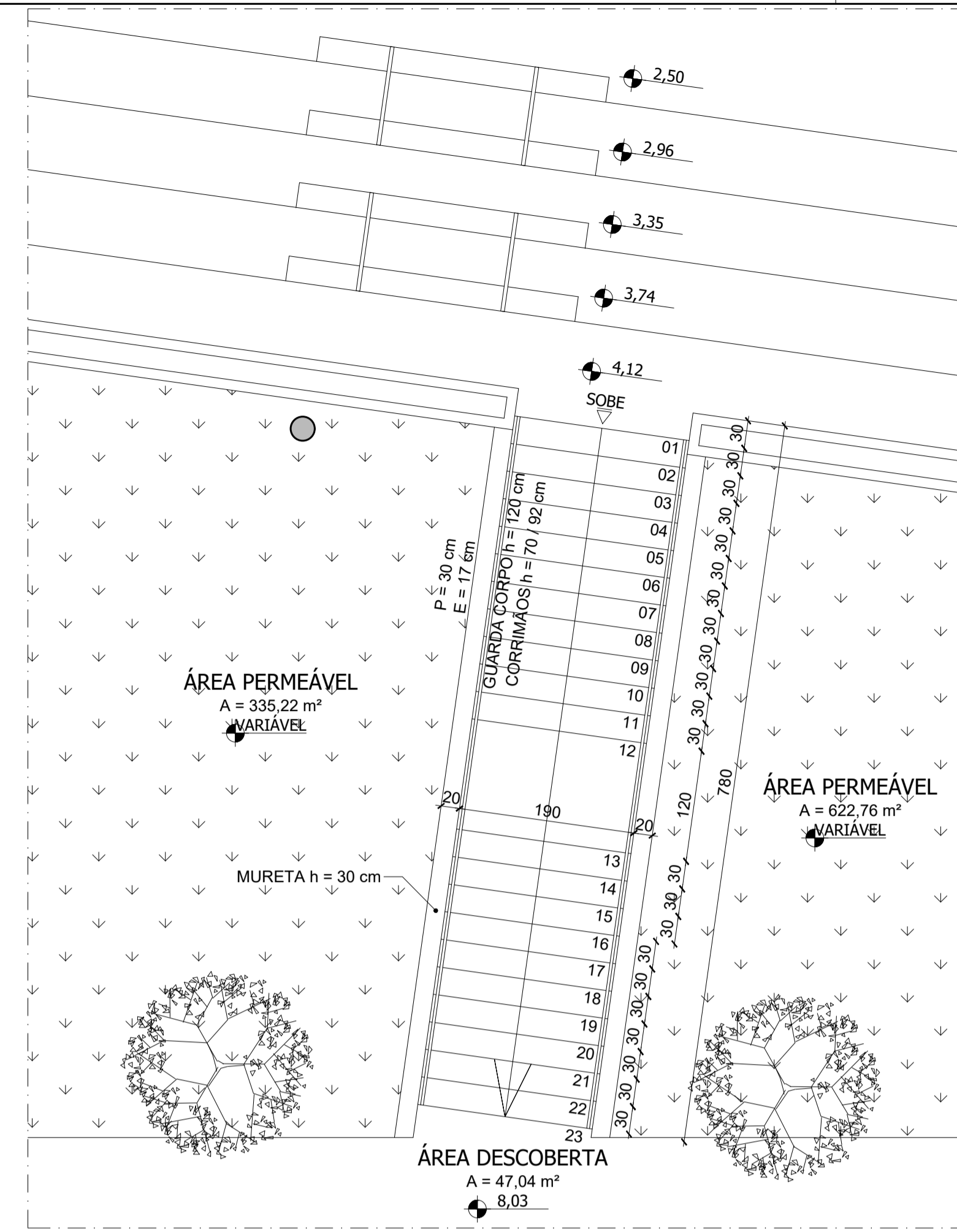

14 PLANTA - ESCADA  
ESCALA 1:50

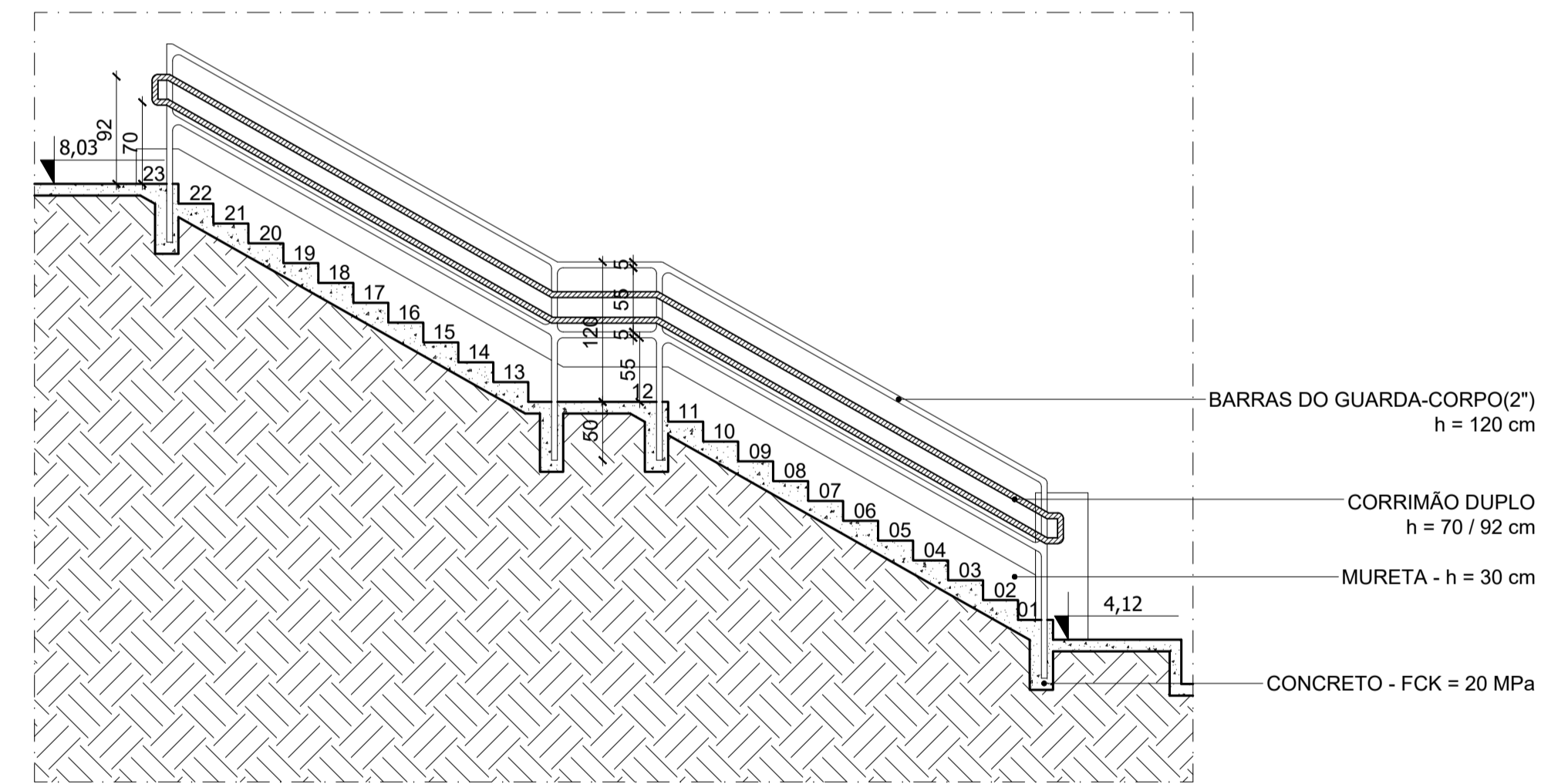

15 SEÇÃO LONGITUDINAL - ESCADA  
ESCALA 1:50

- ELEMENTOS EXISTENTES
- ELEMENTOS A SEREM DEMOLIDOS
- ELEMENTOS A SEREM ACRESCIDOS

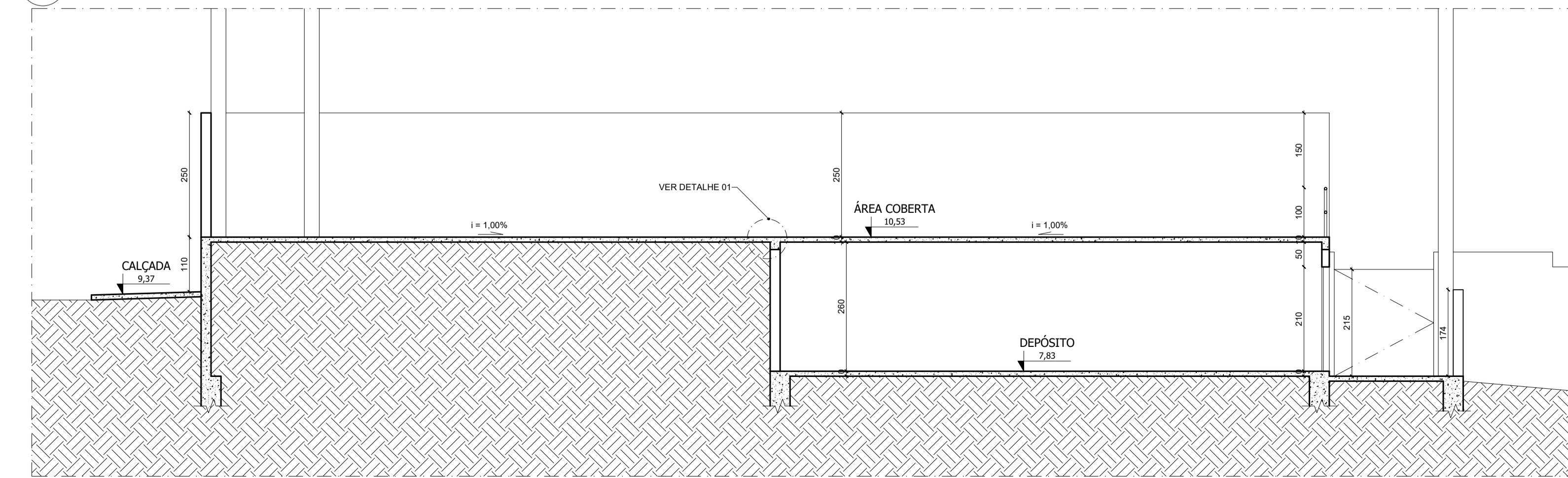

13 CORTE CC  
ESCALA 1:75



**PREFEITURA MUNICIPAL DE IGARATINGA - MG**

**REFORMA DO ESTÁDIO DONA ROGELINA**

LOGRADOURO: RUA CÂNDIDO JOSÉ DA SILVA / RUA JOSÉ BARREIRO / RUA PADRE EVANISTO  
BAIRRO: CENTRO (DISTRITO DE ANTUNES)  
IGARATINGA - MG - CEP: 35695-000

RESPONSÁVEL TÉCNICO:  FLÁVIO L. GRECO S. ENGº CIVIL - CREA-MG: 64.880/D	PROPRIETÁRIO:  PREFEITURA MUNICIPAL DE IGARATINGA CPNJ: 18.313.825/0001-21
ESCALA: INDICADA	DATA: AGOSTO/2023
FOLHA: 10	



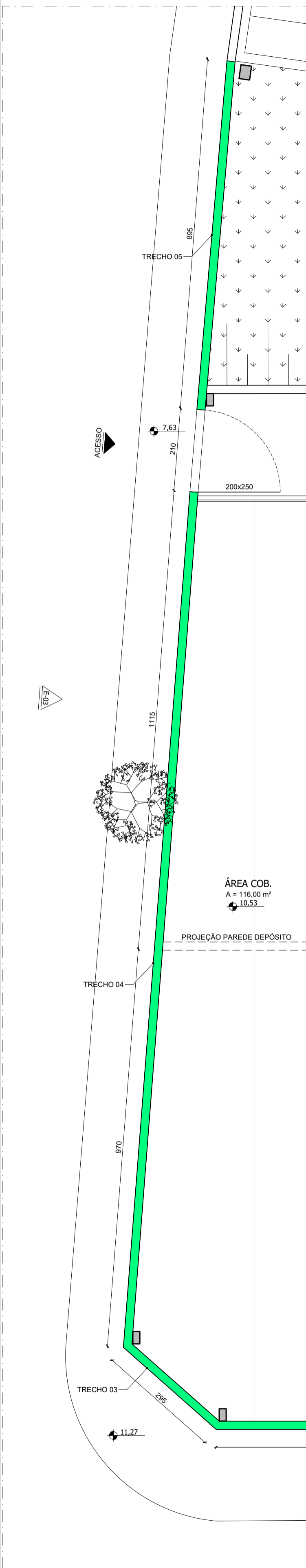

**16 PLANTA - MUROS**  
ESCALA 1:75

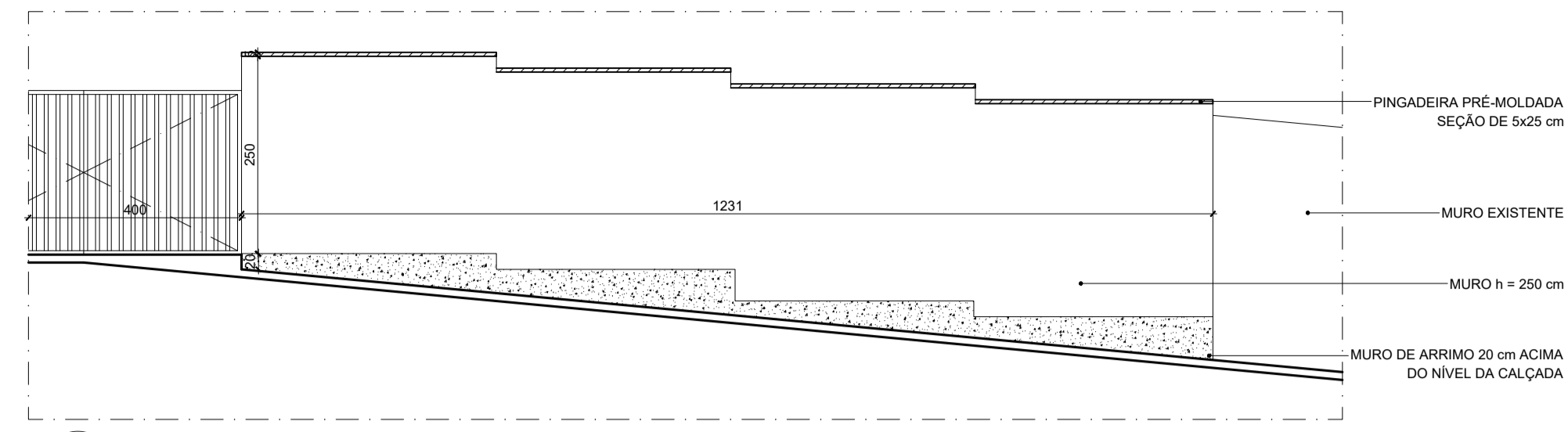

**17 ELEVÇÃO 01**  
ESCALA 1:75

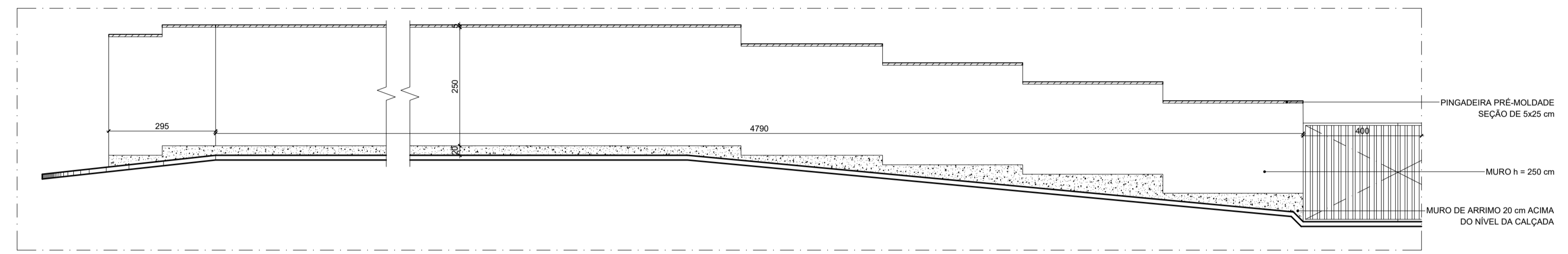

**18 ELEVÇÃO 02**  
ESCALA 1:75

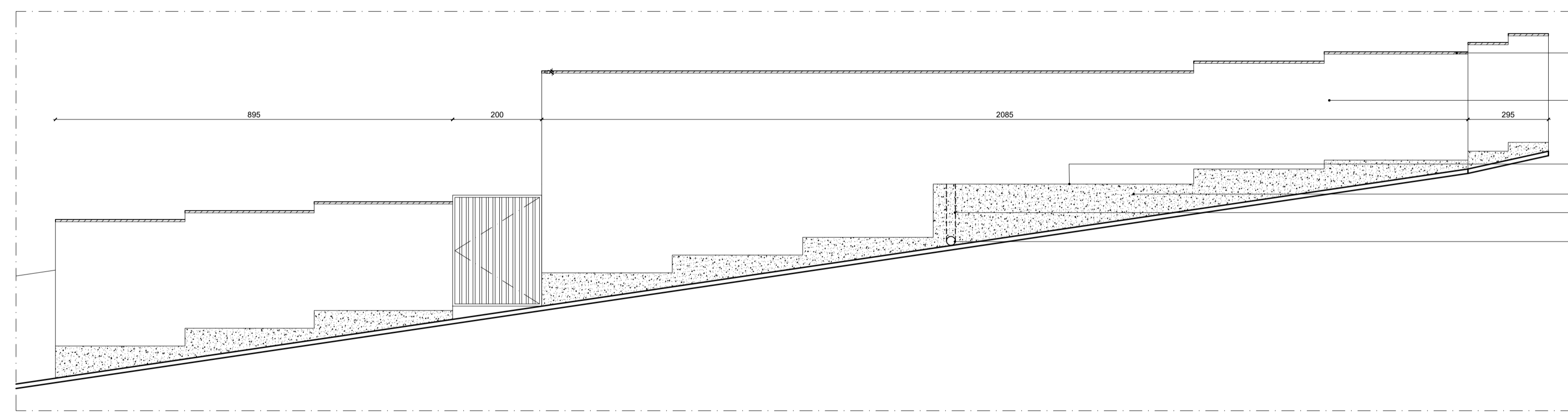

**19 ELEVÇÃO 03**  
ESCALA 1:75

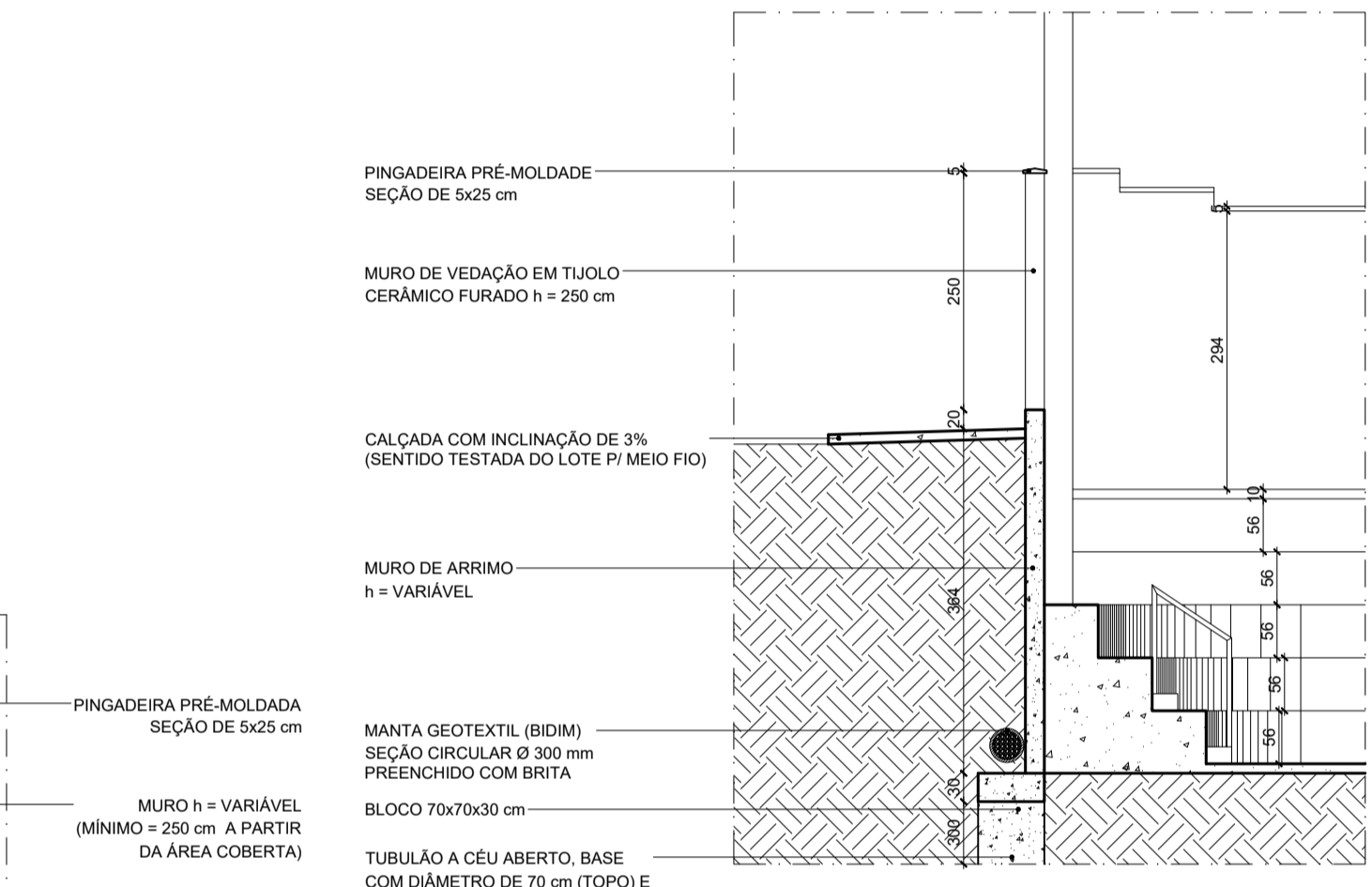

**20 CORTE DD**  
ESCALA 1:75

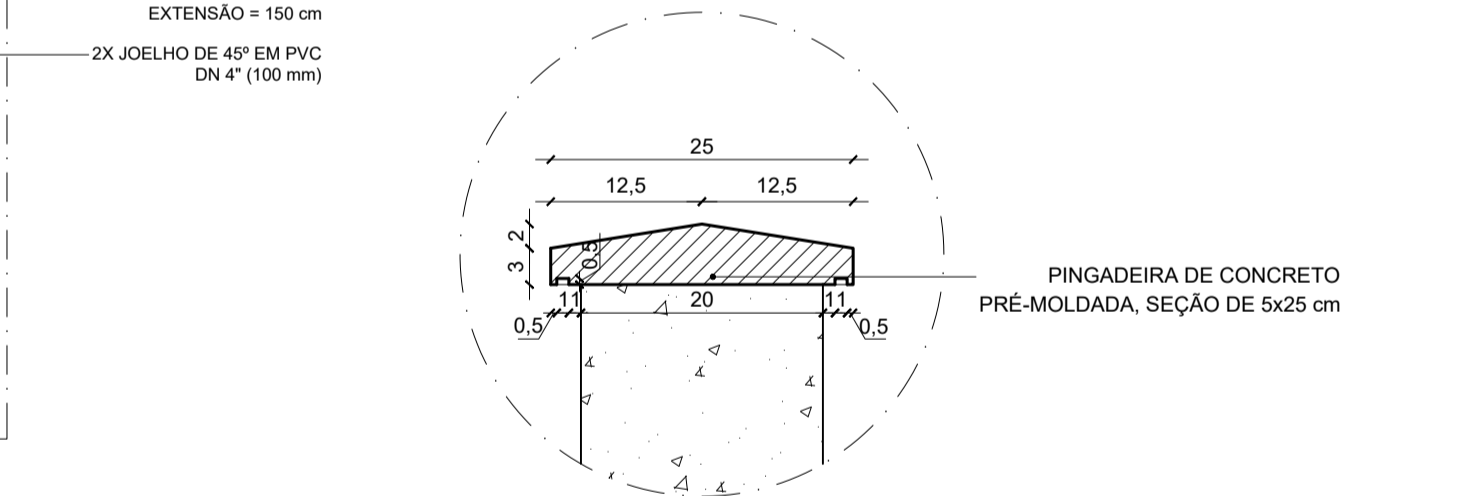

**21 DETALHE PINGADEIRA**  
ESCALA 1:5

- ELEMENTOS EXISTENTES
- ELEMENTOS A SEREM DEMOLIDOS
- ELEMENTOS A SEREM ACRESCIDOS



**PREFEITURA MUNICIPAL DE IGARATINGA - MG**

---

**REFORMA DO ESTÁDIO DONA ROGELINA**

---

LOGRADOURO: RUA CÂNDIDO JOSÉ DA SILVA / RUA JOSÉ BARREIRO / RUA PADRE EVANISTO  
BAIRRO: CENTRO (DISTRITO DE ANTUNES)  
IGARATINGA - MG CEP: 35695-000

RESPONSÁVEL TÉCNICO:  FLÁVIO L. GRECO S. ENGº CIVIL - CREA-MG: 64.880/D	PROPRIETÁRIO:  PREFEITURA MUNICIPAL DE IGARATINGA CPNJ: 18.313.825/0001-21
ESCALA: INDICADA	DATA: AGOSTO/2023
FOLHA: 11	



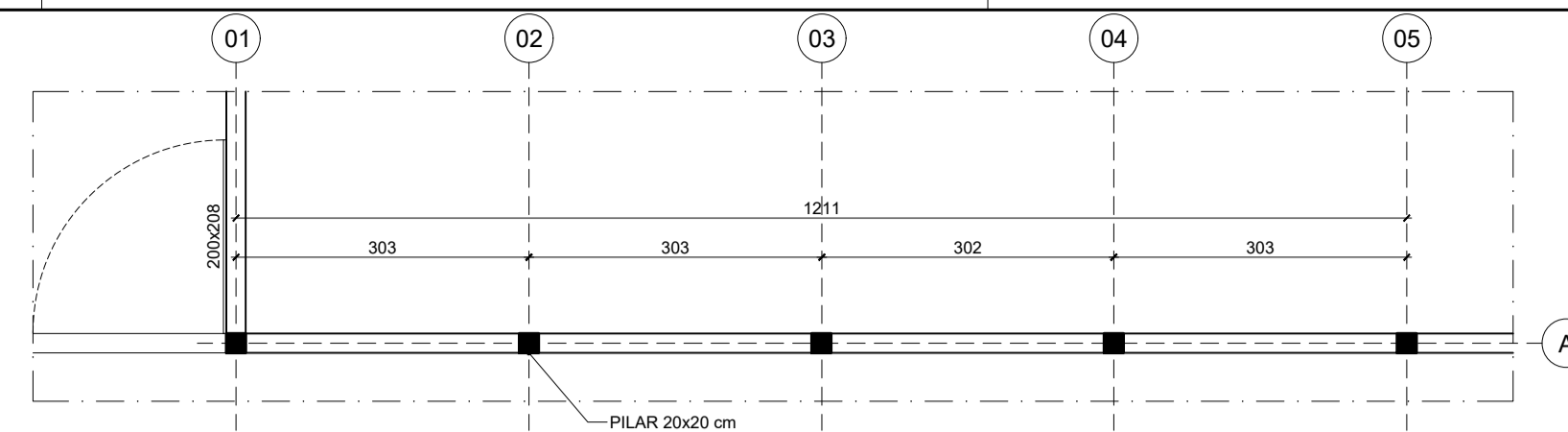

22 PLANTA PILARES - TRECHO 01  
ESCALA 1:75

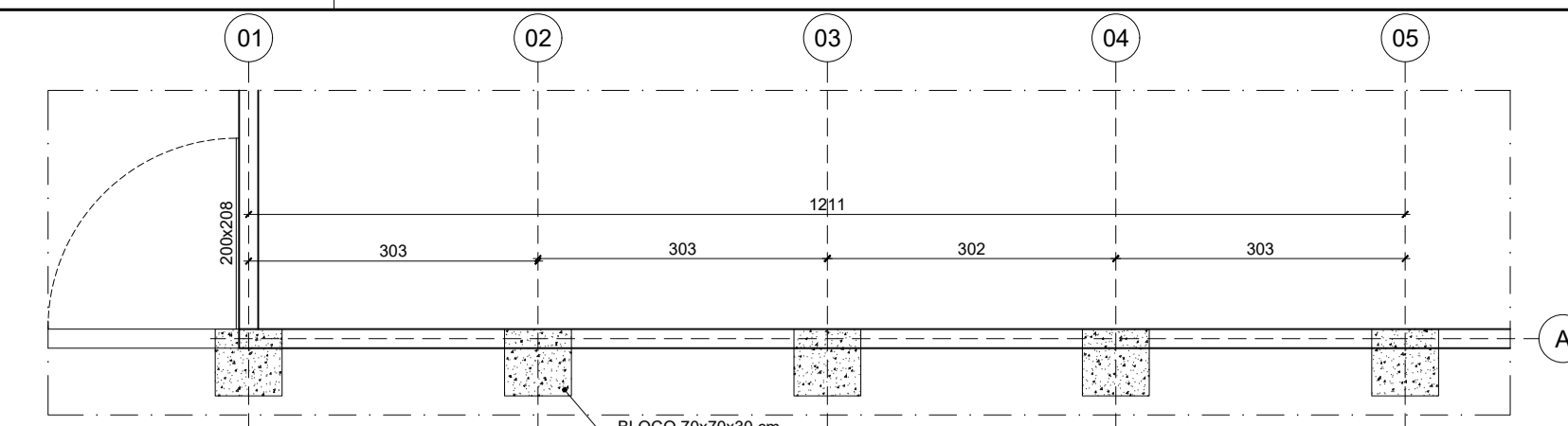

23 PLANTA ESTACAS - TRECHO 01  
ESCALA 1:75

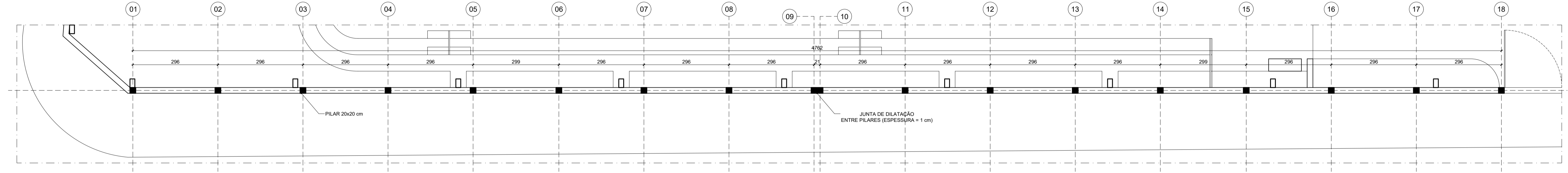

24 PLANTA PILARES - TRECHO 02  
ESCALA 1:75

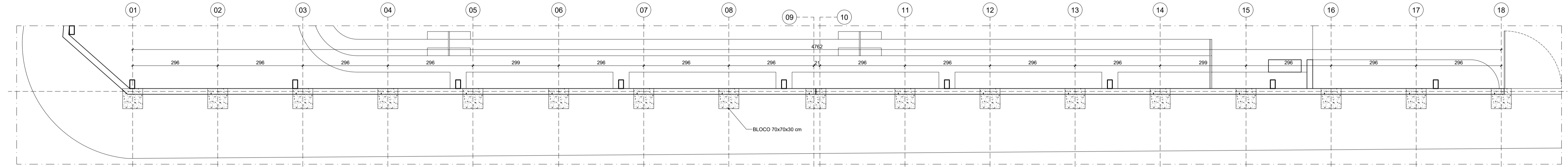

25 PLANTA ESTACAS - TRECHO 02  
ESCALA 1:75

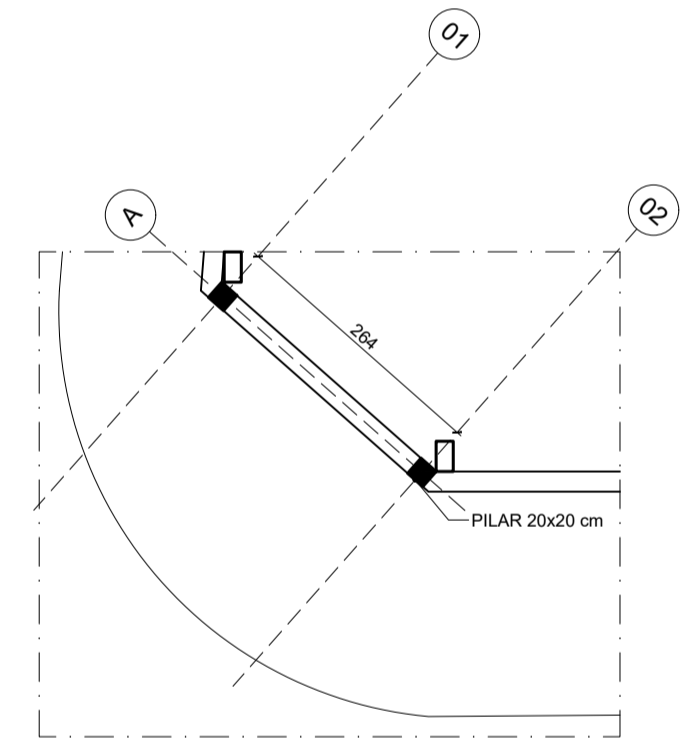

26 PLANTA PILARES - TRECHO 03  
ESCALA 1:75

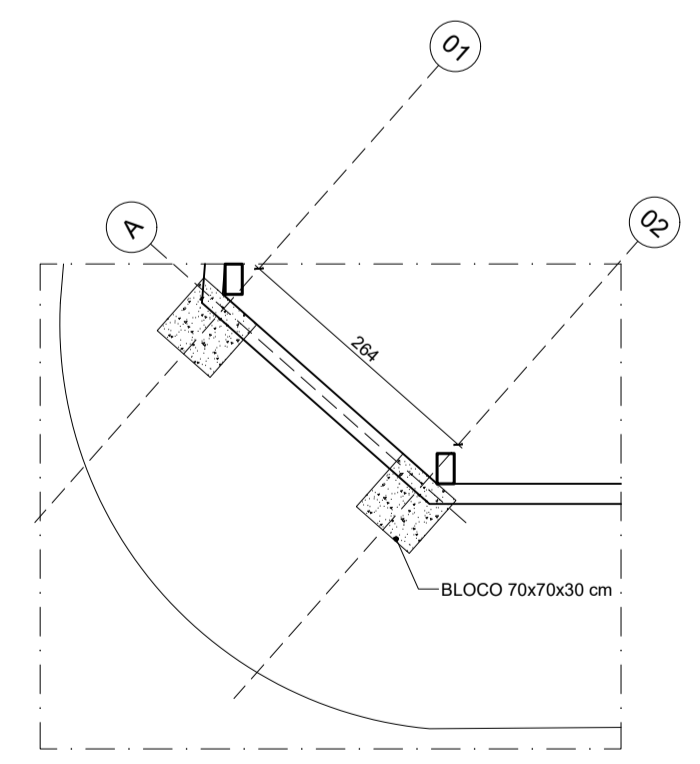

27 PLANTA ESTACAS - TRECHO 03  
ESCALA 1:75

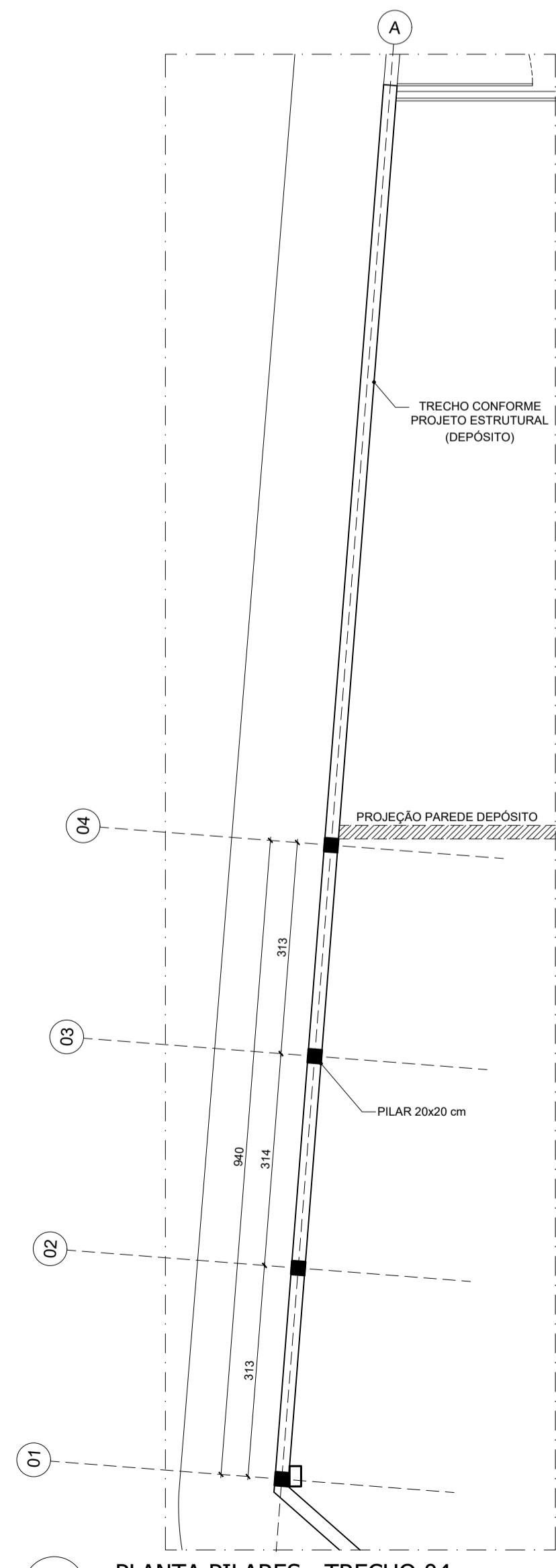

28 PLANTA PILARES - TRECHO 04  
ESCALA 1:75

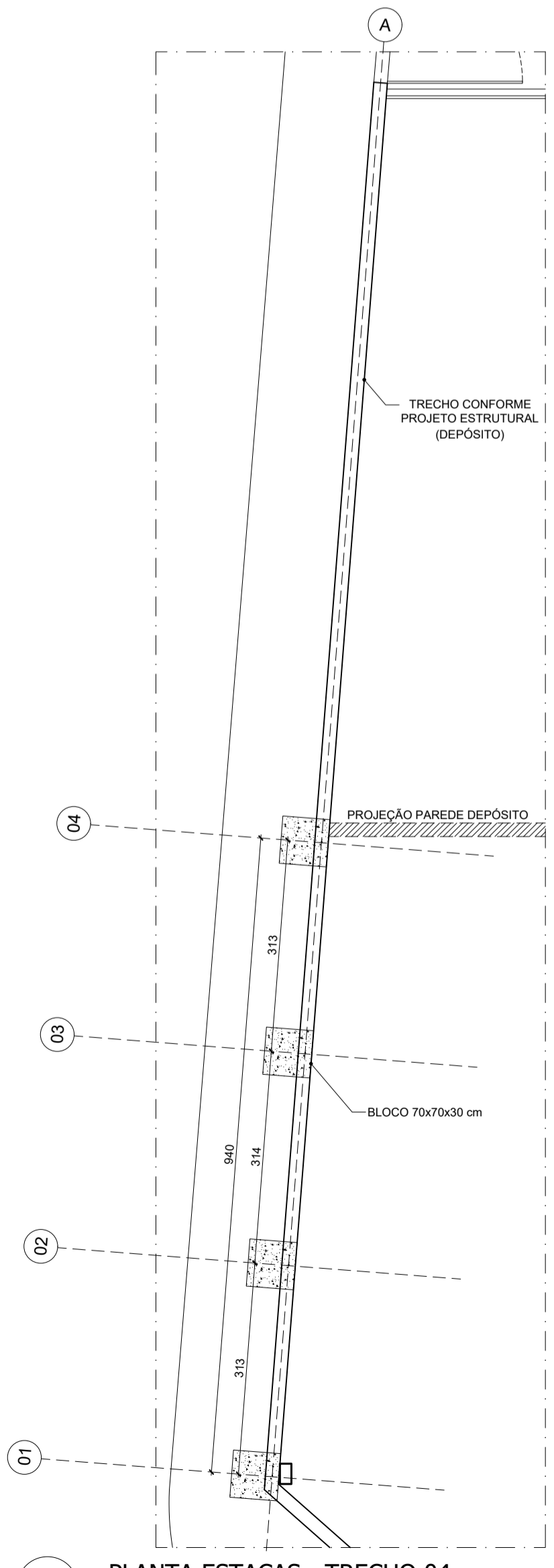

29 PLANTA ESTACAS - TRECHO 04  
ESCALA 1:75

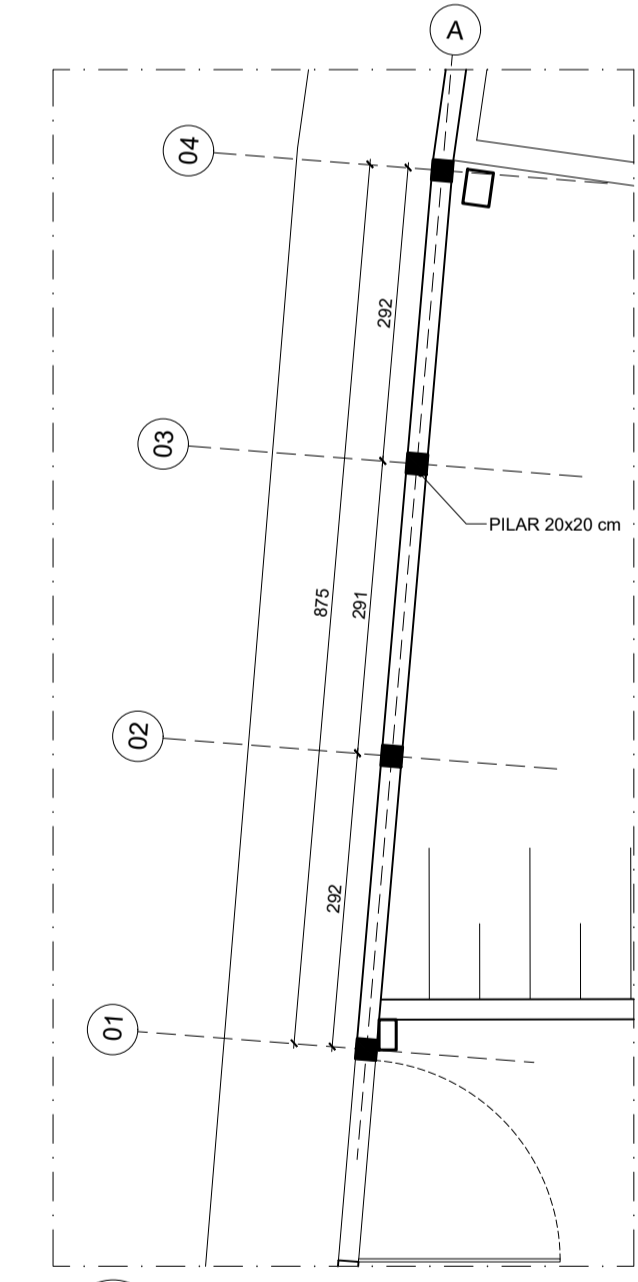

30 PLANTA PILARES - TRECHO 05  
ESCALA 1:75

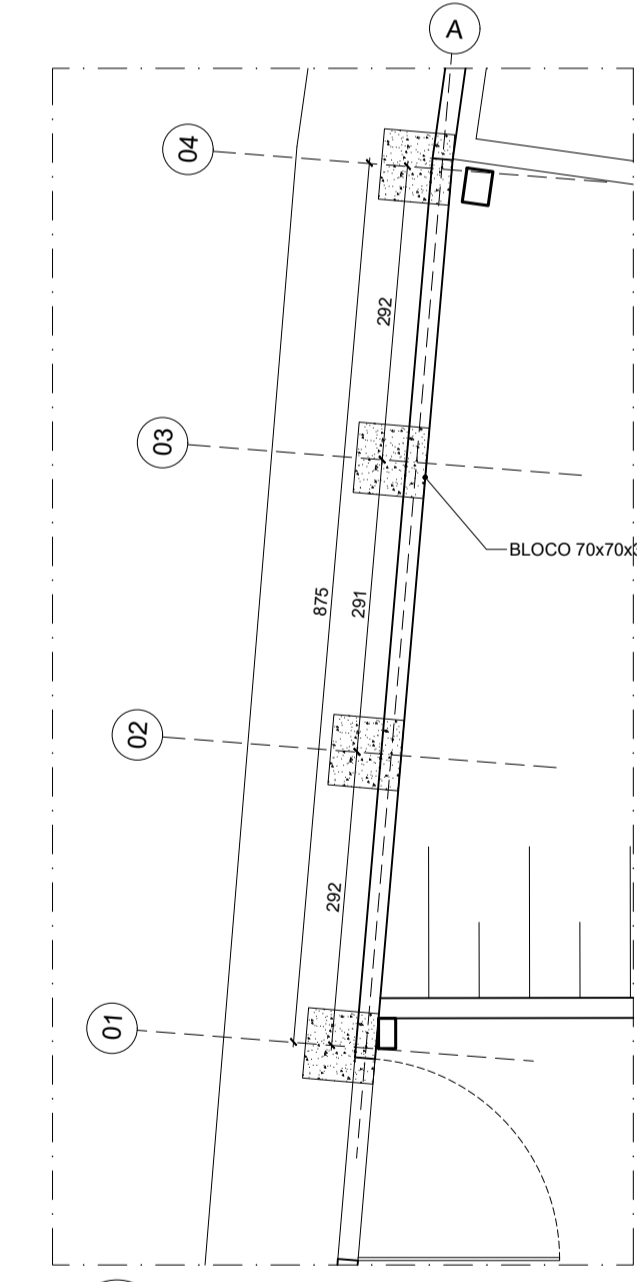

31 PLANTA ESTACAS - TRECHO 05  
ESCALA 1:75

- ELEMENTOS EXISTENTES
- ELEMENTOS A SEREM DEMOLIDOS
- ELEMENTOS A SEREM ACRESCIDOS



## PREFEITURA MUNICIPAL DE IGARATINGA - MG

### REFORMA DO ESTÁDIO DONA ROGELINA

LOGRADOURO: RUA CÂNDIDO JOSÉ DA SILVA / RUA JOSÉ BARREIRO / RUA PADRE EVANISTO  
BAIRRO: CENTRO (DISTRITO DE ANTUNES)  
IGARATINGA - MG CEP: 35695-000

RESPONSÁVEL TÉCNICO:  FLÁVIO L. GRECO S. ENGRº CIVIL - CREA-MG: 64.880/D	PROPRIETÁRIO:  PREFEITURA MUNICIPAL DE IGARATINGA CPNJ: 18.313.825/0001-21
ESCALA: INDICADA	DATA: AGOSTO/2023
FOLHA: 12	(Empty space)



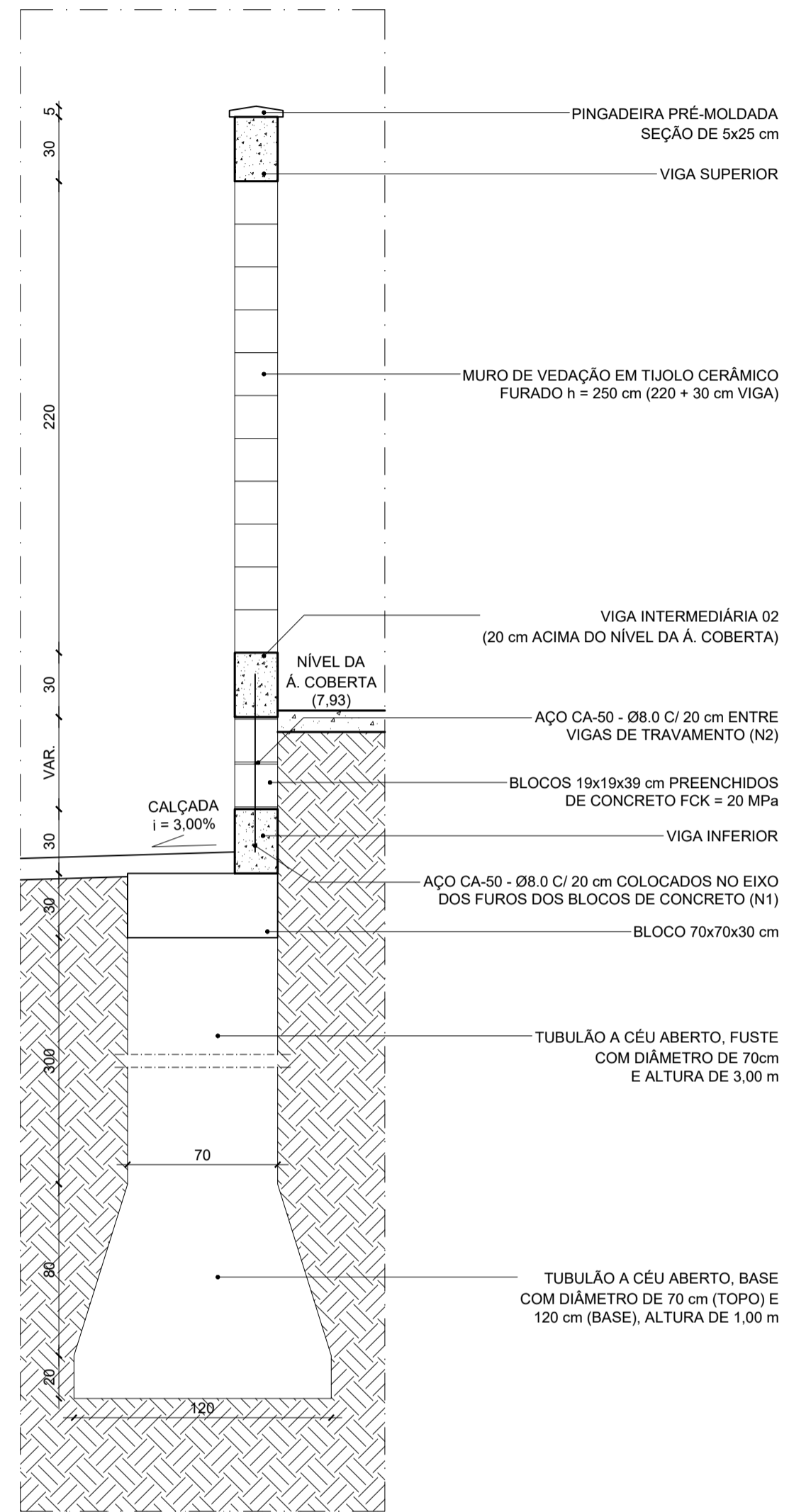

32 SEÇÃO TRANSVERSAL - TRECHO 01  
ESCALA 1:25

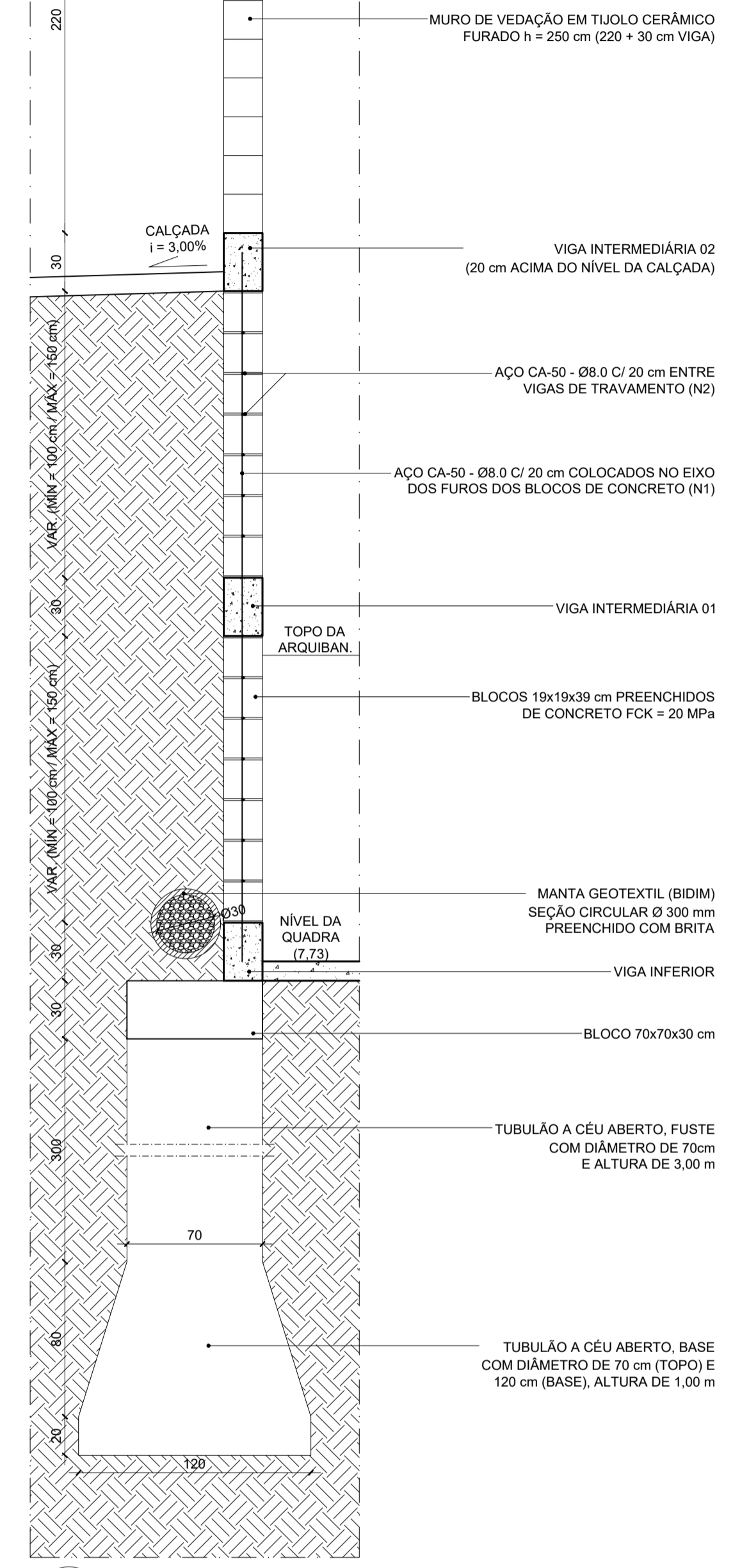

33 SEÇÃO TRANSVERSAL - TRECHOS 02/03  
ESCALA 1:25

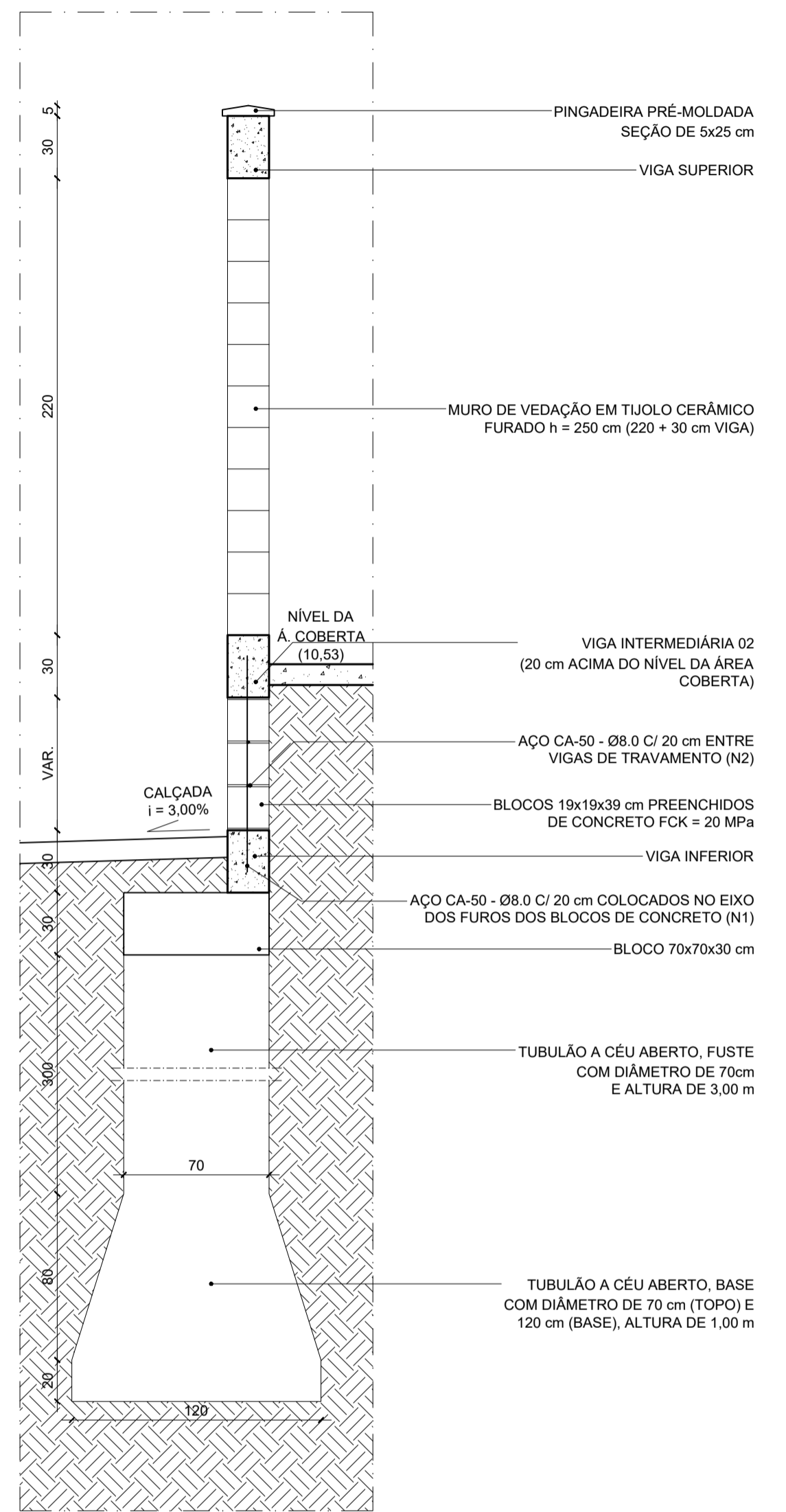

34 SEÇÃO TRANSVERSAL - TRECHO 04  
ESCALA 1:25

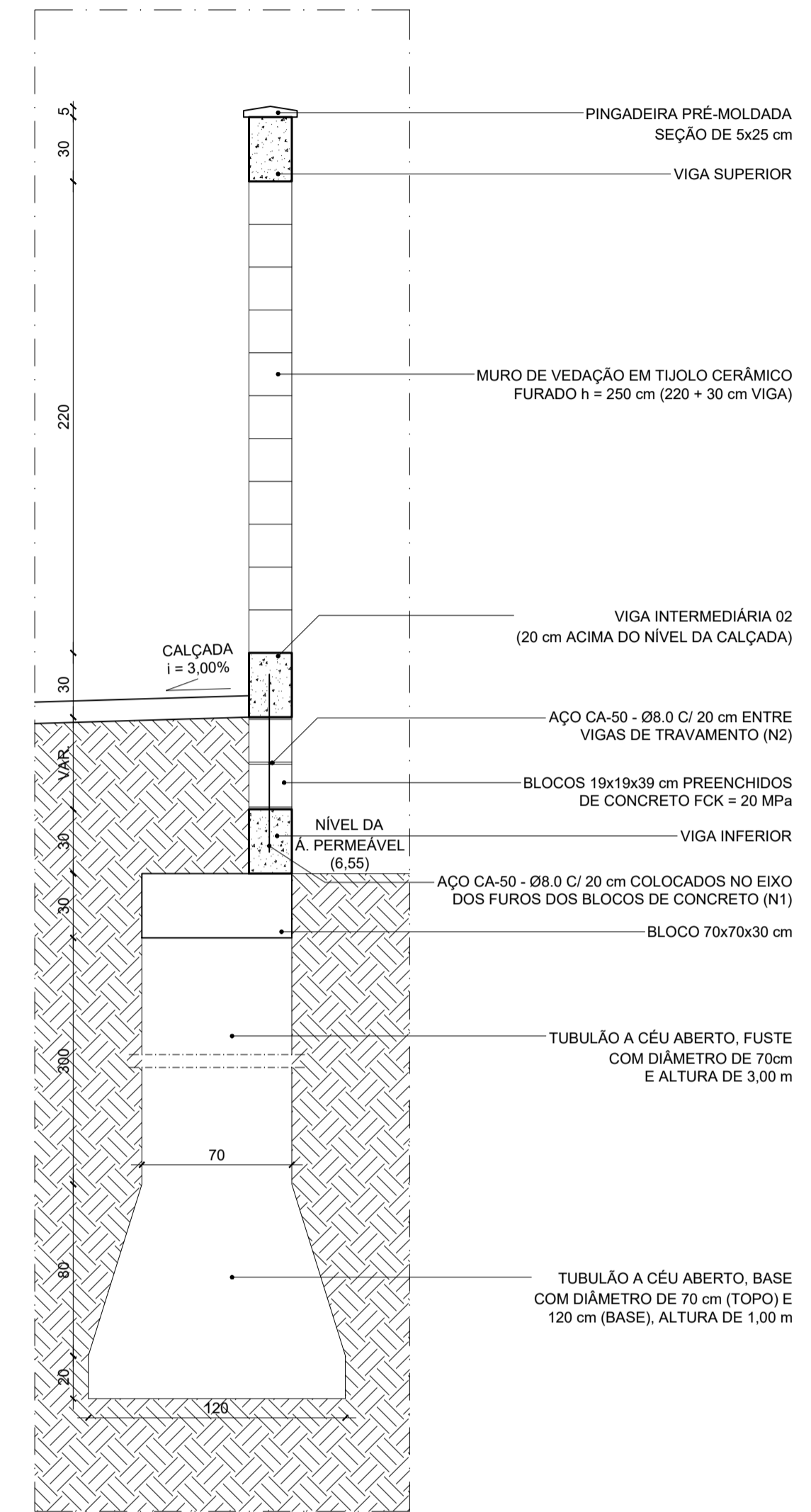

35 SEÇÃO TRANSVERSAL - TRECHO 05  
ESCALA 1:25

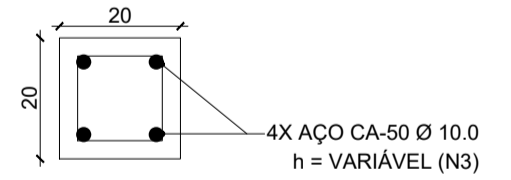

36 DETALHE PILARES  
ESCALA 1:10

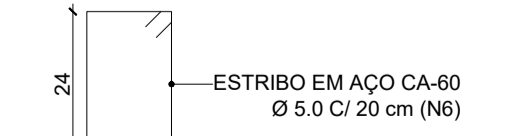
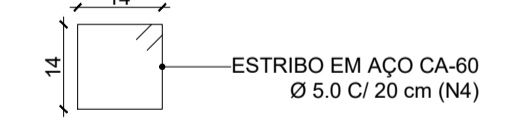

37 DET. VIGA INFERIOR / INTERMEDIÁRIA 01  
ESCALA 1:5

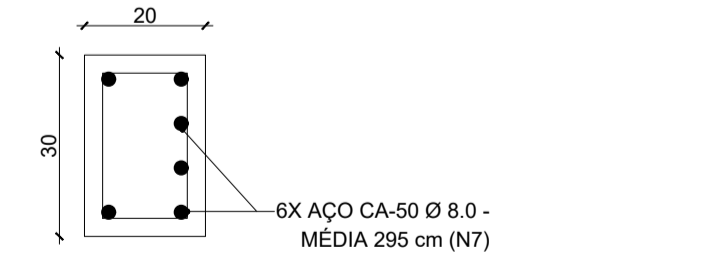

38 DET. VIGA INTERMEDIÁRIA 02 / SUPERIOR  
ESCALA 1:5

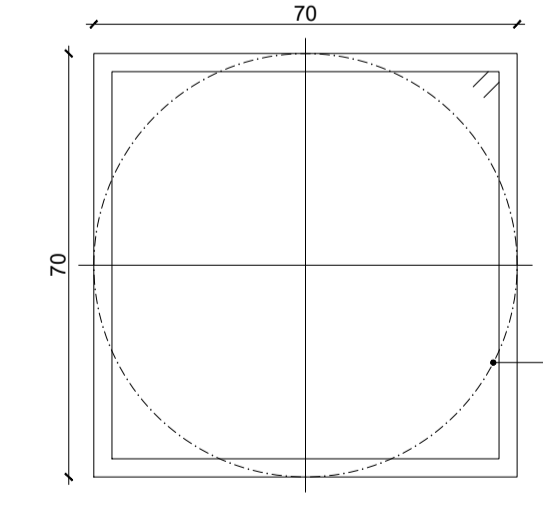

39 DETALHE BLOCOS (PLANTA)  
ESCALA 1:5

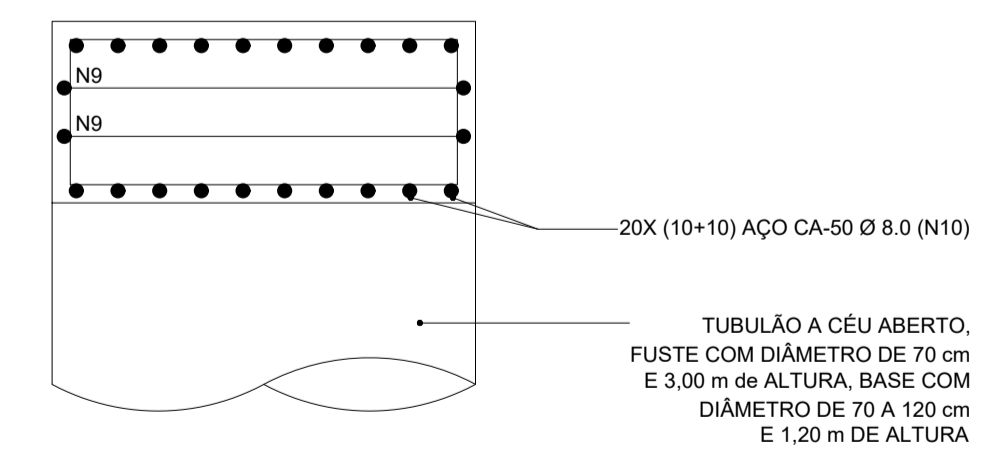

40 DETALHE BLOCOS (VISTA)  
ESCALA 1:5

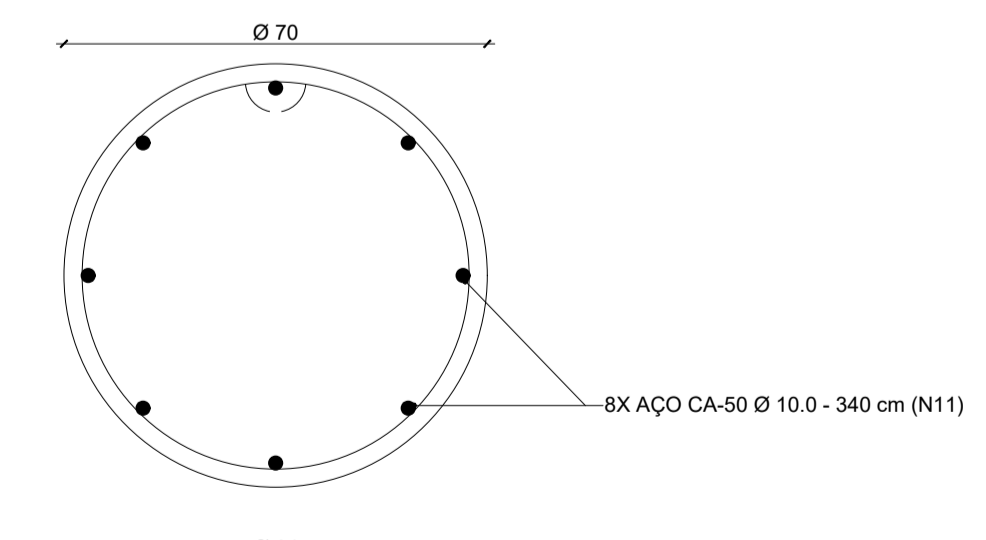

41 DETALHE ESTACAS  
ESCALA 1:5

RESUMO AÇO	IDENTIFICAÇÃO	COMP. TOTAL. (m)	PESO (Kg)
CA-50 Ø8.0	N1	979,88	387,05
CA-50 Ø8.0	N2	642,78	253,90
CA-50 Ø10.0	N3	695,72	429,26
CA-60 Ø5.0	N4	579,48	89,24
CA-50 Ø8.0	N5	976,88	385,87
CA-60 Ø5.0	N6	532,34	81,98
CA-50 Ø8.0	N7	902,28	356,40
CA-60 Ø5.0	N8	655,32	100,92
CA-50 Ø6.3	N9	167,68	41,08
CA-50 Ø8.0	N10	1.190,40	470,21
CA-50 Ø10.0	N11	870,40	537,04
CA-60 Ø5.0	N12	964,80	148,58
TOTAL CA-50 Ø6.3 (0,245 Kg/m)			41,08
TOTAL CA-50 Ø8.0 (0,395 Kg/m)			1.853,43
TOTAL CA-50 Ø10.0 (0,617 Kg/m)			966,30
TOTAL CA-60 Ø5.0 (0,154 Kg/m)			420,72

- ELEMENTOS EXISTENTES
- ELEMENTOS A SEREM DEMOLIDOS
- ELEMENTOS A SEREM ACRESCIDOS



## PREFEITURA MUNICIPAL DE IGARATINGA - MG

### REFORMA DO ESTÁDIO DONA ROGELINA

LOGRADOURO: RUA CÂNDIDO JOSÉ DA SILVA / RUA JOSÉ BARREIRO / RUA PADRE EVANISTO  
BAIRRO: CENTRO (DISTRITO DE ANTUNES)  
IGARATINGA - MG CEP: 35695-000

RESPONSÁVEL TÉCNICO: FLÁVIO L. GRECO S.  
ENGRº CIVIL - CREA-MG: 64.880/D

PROPRIETÁRIO: PREFEITURA MUNICIPAL DE IGARATINGA  
CPNJ: 18.313.825/0001-21

ESCALA: INDICADA DATA: AGOSTO/2023 FOLHA: 13



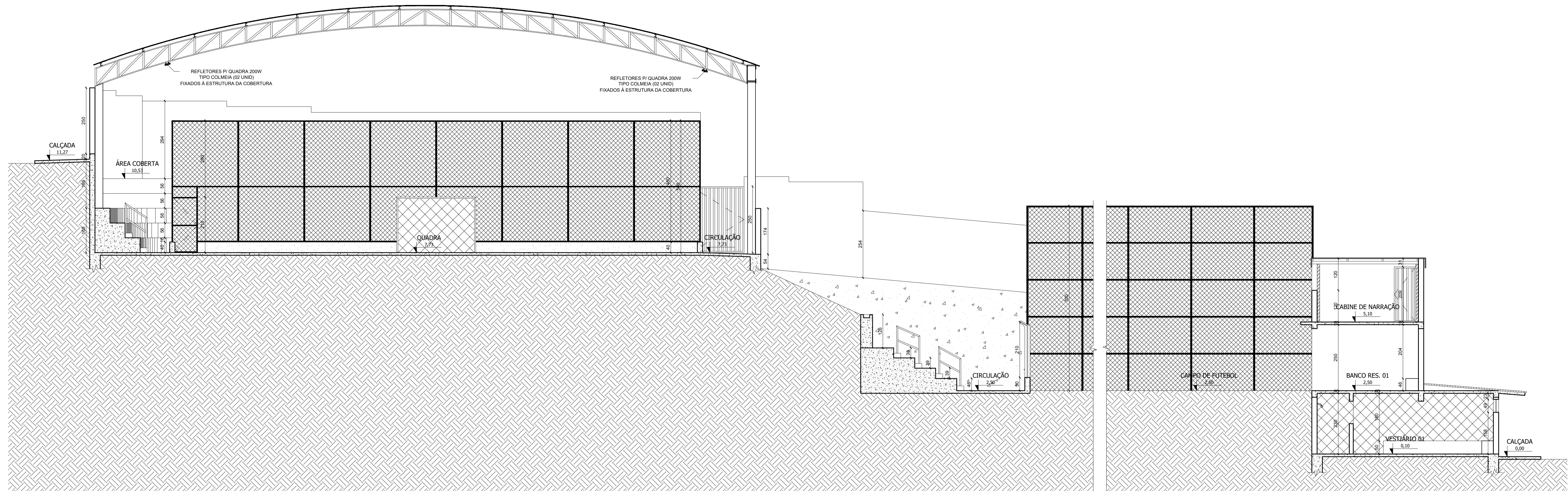

42 CORTE EE  
ESCALA 1:75

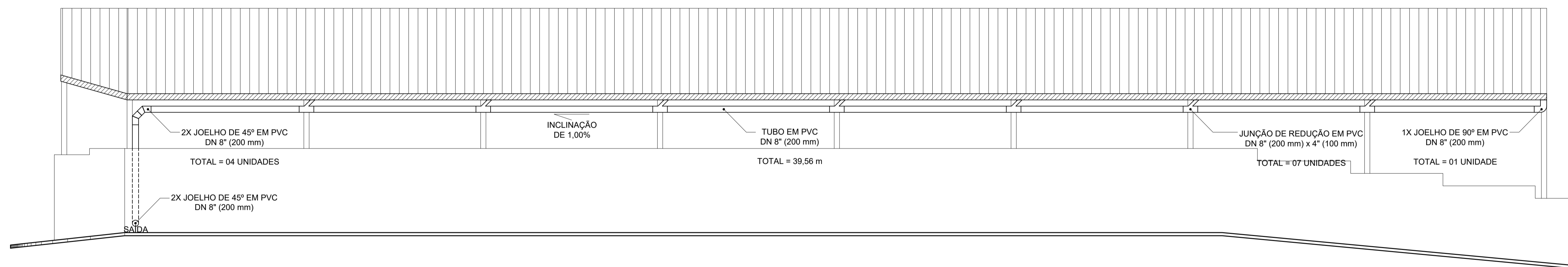

43 DETALHE DRENAGEM (ELEVÇÃO RUA)  
ESCALA 1:75

- ELEMENTOS EXISTENTES
- ELEMENTOS A SEREM DEMOLIDOS
- ELEMENTOS A SEREM ACRESCIDOS



**PREFEITURA MUNICIPAL DE IGARATINGA - MG**

---

**REFORMA DO ESTÁDIO DONA ROGELINA**

---

LOGRADOURO: RUA CÂNDIDO JOSÉ DA SILVA / RUA JOSÉ BARREIRO / RUA PADRE EVANISTO  
BAIRRO: CENTRO (DISTRITO DE ANTUNES)  
IGARATINGA - MG CEP: 35695-000

RESPONSÁVEL TÉCNICO:  FLÁVIO L. GRECO S. ENGº CIVIL - CREA-MG: 64.880/D	PROPRIETÁRIO:  PREFEITURA MUNICIPAL DE IGARATINGA CPNJ: 18.313.825/0001-21
--	---

---

ESCALA: 1/75	DATA: AGOSTO/2023	FOLHA: 14
--------------	-------------------	-----------



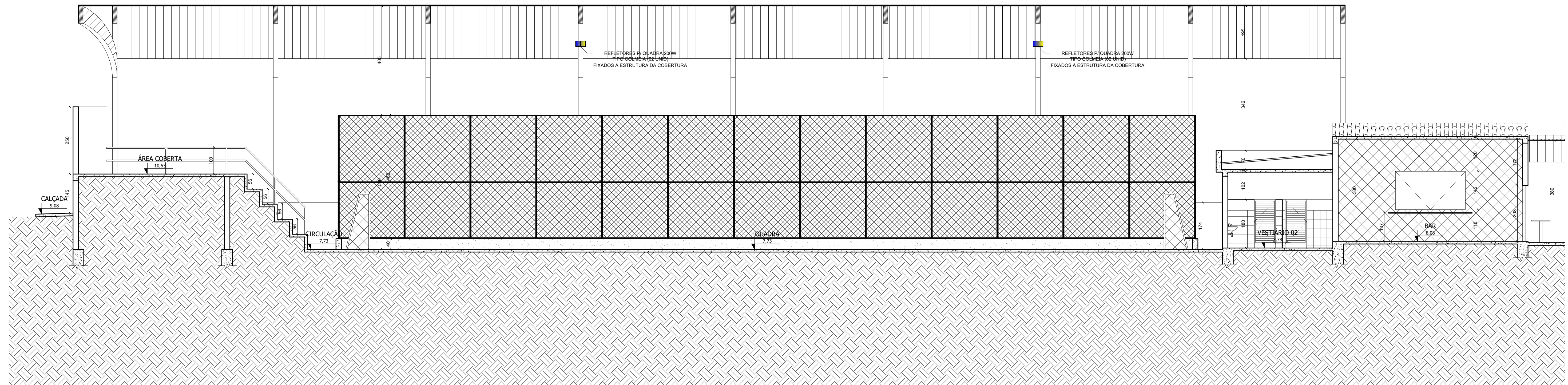

44 CORTE FF  
ESCALA 1:75

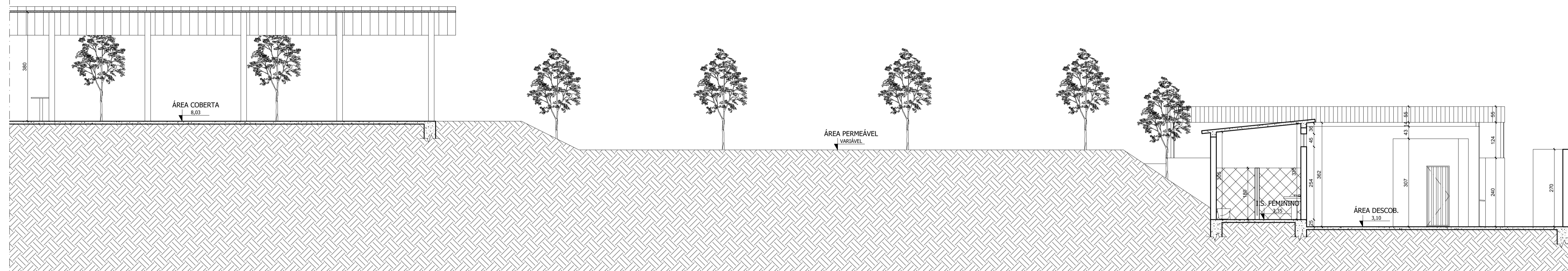

45 CORTE FF (CONTINUAÇÃO)  
ESCALA 1:75

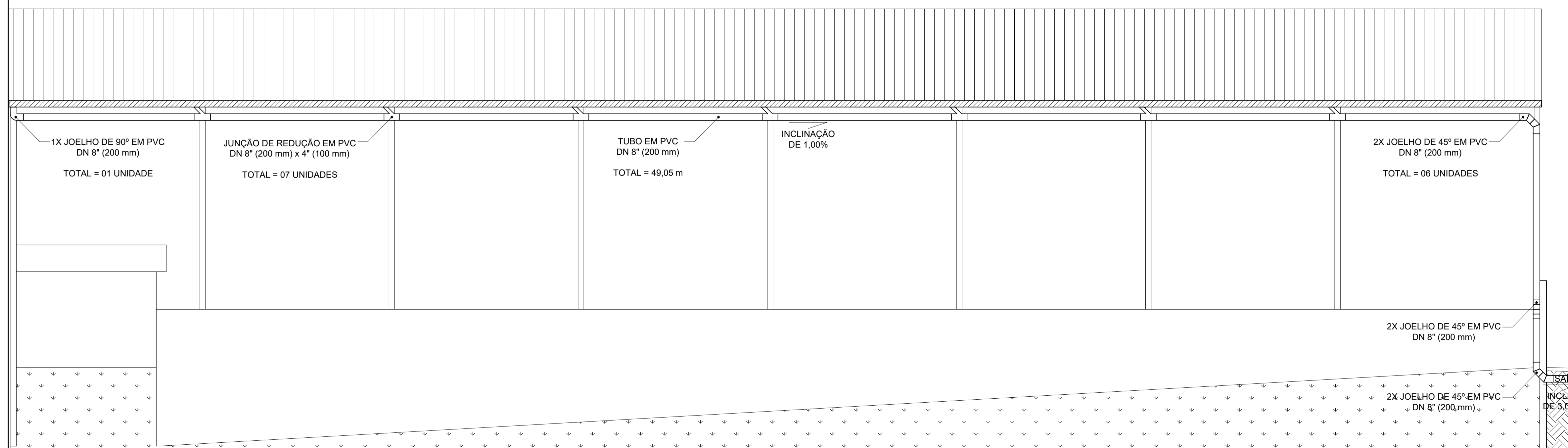

46 DETALHE DRENAGEM (ELEVÇÃO CAMPO)  
ESCALA 1:75

- ELEMENTOS EXISTENTES
- ELEMENTOS A SEREM DEMOLIDOS
- ELEMENTOS A SEREM ACRESCIDOS



**PREFEITURA MUNICIPAL DE IGARATINGA - MG**

**REFORMA DO ESTÁDIO DONA ROGELINA**

LOGRADOURO: RUA CÂNDIDO JOSÉ DA SILVA / RUA JOSÉ BARREIRO / RUA PADRE EVANISTO  
BAIRRO: CENTRO (DISTRITO DE ANTUNES)  
IGARATINGA - MG CEP: 35695-000

RESPONSÁVEL TÉCNICO:	PROPRIETÁRIO:
FLÁVIO L. GRECO S. ENGº CIVIL - CREA-MG: 64.880/D	PREFEITURA MUNICIPAL DE IGARATINGA CPNJ: 18.313.825/0001-21
ESCALA: 1/75	DATA: AGOSTO/2023
	FOLHA: 15